

*F2, F1600* **CHAPTER 7**

## **Rounded Half-Blind Finger Joint Procedures**

*Rounded Finger Joints can only be created using  
the 24" [600mm) F2 and F2M.*

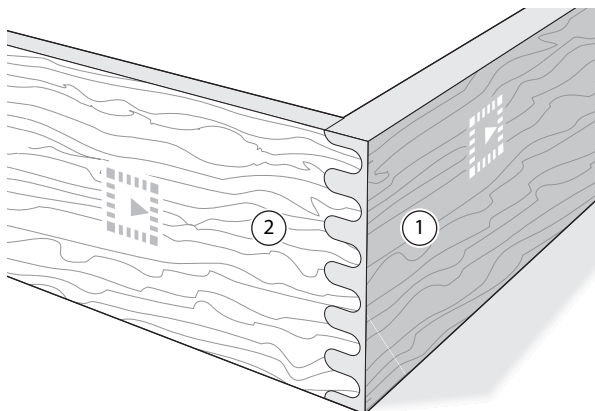





### 7-1 F2-24" and F2M(600mm) Only

Rounded half-blind finger joints make an attractive drawer front ① to side ② connection.

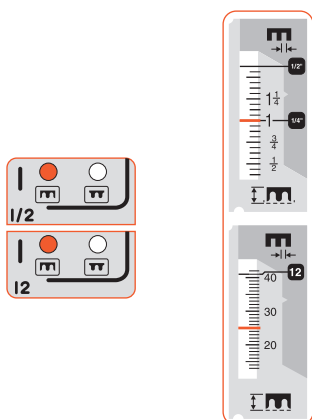
*Before starting, check the board width charts on pages 32-33 and see Appendix II for cutter selection.*



### 7-2 Routing Half-Blind Joints

Set the template scale to the thickness of the pin board on the grey scale, e.g. 1" [25mm] shown here. Set the template pin in the  hole.

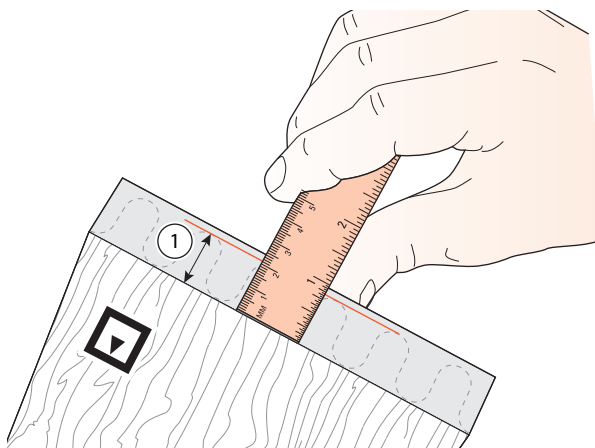

### 7-3

Measure the required depth of horizontal cut into the pin board ①, usually  $\frac{1}{8}$ " [3mm] less than the board thickness.

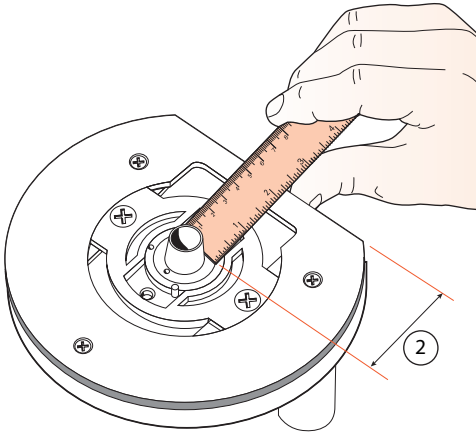

**7-4**  
Measure the distance from the guidebush to the rear edge of the router base ②.

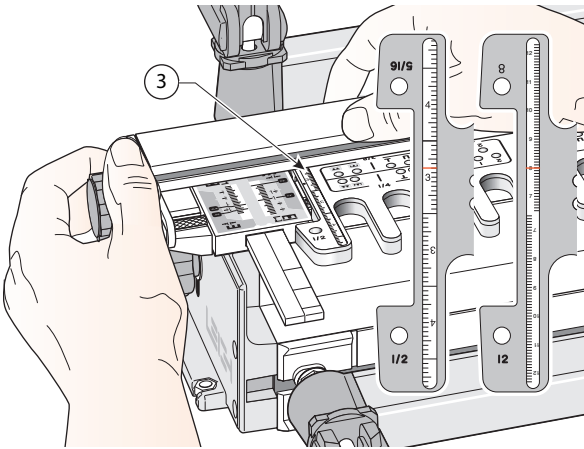

**7-5**  
Add dimensions ① and ②. Set the router stop fence to this total on the fence scale ③ at both ends of the template. Tighten the fence knobs. If your router base is small, see 7-6 below.

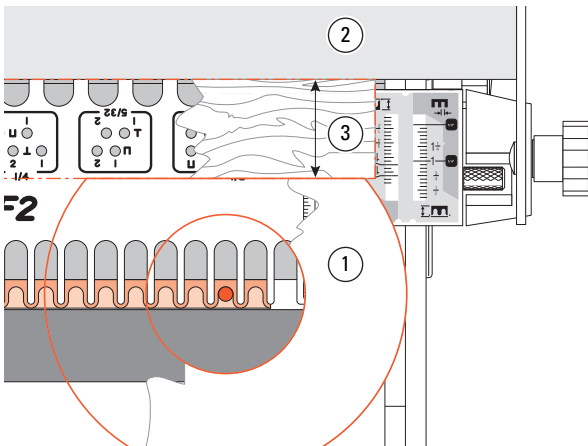

**7-6**  
Some router bases ① are quite small and it may not be possible to get the router fence ② far enough forward to be effective. Use a parallel-sided block ③ between the router and fence. Offset the fence setting by the width of the block.

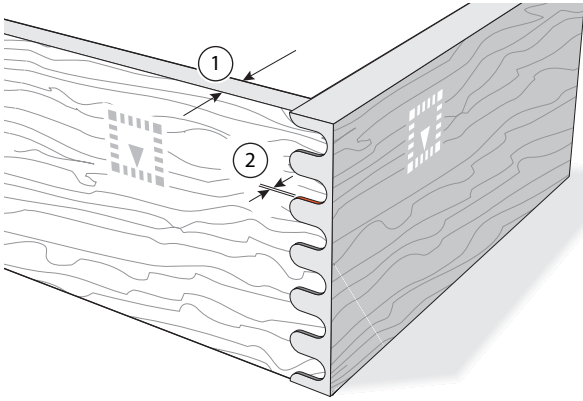
**7-7**

Set the depth of cut to slightly greater than the thickness of the side board ①. You want the drawer front fingers to come through the side sockets by no more than  $\frac{1}{64}$ " [0,25mm] ② for cleanup later, just like half-blind dovetails.

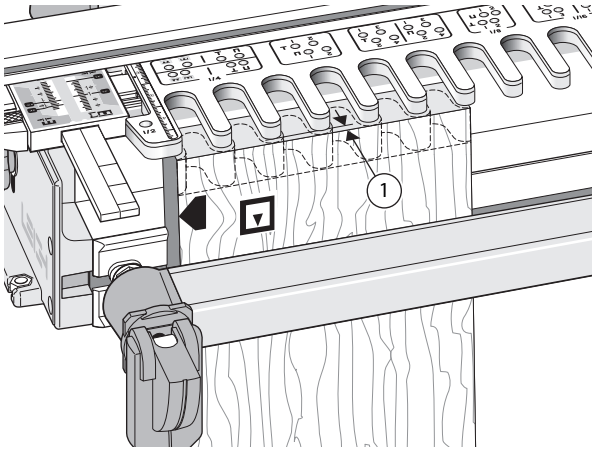
**7-8**

Clamp the pin board vertically against the side stop with the end edge flush under the template. The inside face ② of the finished boards face away from the jig body. With the scale set on the pin board thickness, the board should project  $\frac{1}{8}$ " [3mm] in front of the guide tips ①.

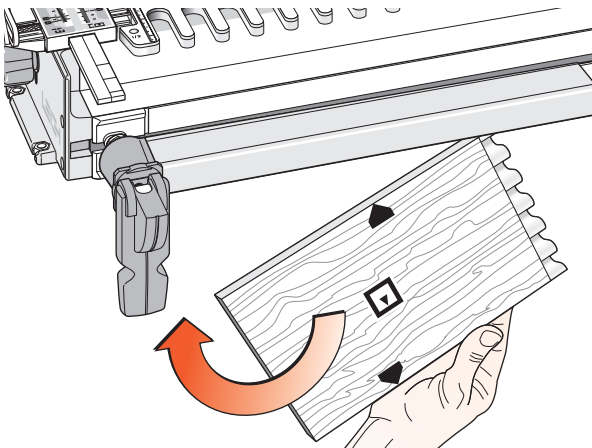
**7-9**

The inside face ② of all boards used for making rounded half-blind joints always face away from the jig body just like half-blind dovetail boards on the dovetail jig. So alternate side edges go against the side stop and boards must all be exactly the same width.

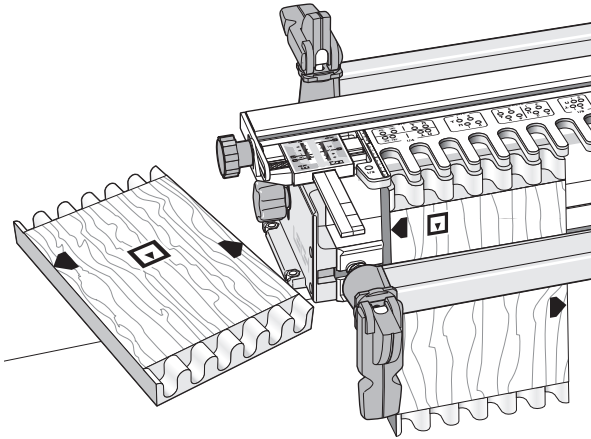

7-10

Rout the rounded pins. Do not push against the router fence. The router should just touch the fence. Rout both ends of both pin boards at this setting. Do not change the fence setting.

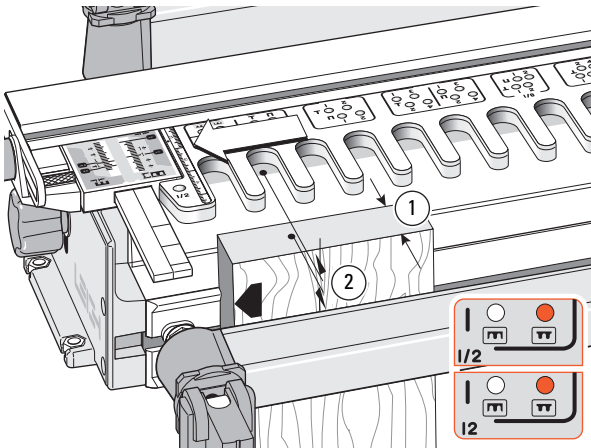

7-11

Insert the template pin in the  hole. Do not change any other setting. Clamp a scrap board ① of exactly the same thickness as the pin board in the front clamp, with the top end edge slightly below the top surface of the jig body ②.

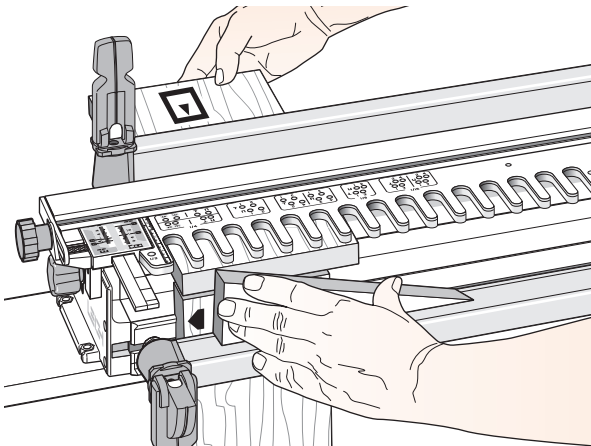

7-12

Clamp one of the box side boards horizontally in the rear clamp, with the inside face  of the board facing away from the jig body and the end edge flush with the outer edge of the vertical scrap board.

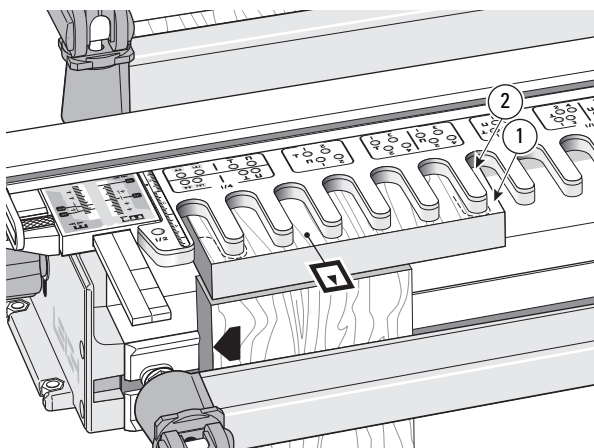

*Tear-out Warning! Do not rout this board before reading the following:*

**7-13**

If you rout this horizontal board in the conventional way you may tear away the right hand board edge ①, although some woods will rout quite cleanly. If a plunge router is used, gently plunge down at the rear of the socket ② and rout out toward you.

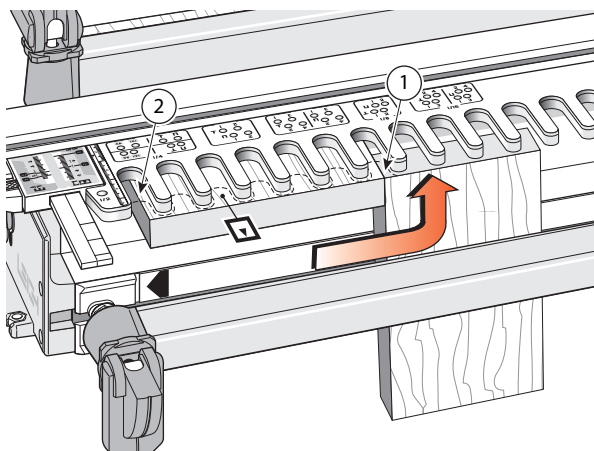
**7-14**

When using combs at the left end of the jig, the best way to avoid the right-edge tearout problem is to clamp the front scrap ① against the right side edge of the board. Simply clamp it under the front clamp bar, making sure it's firmly against the edge of the board. By rotating and flipping its position, one scrap will be good for 4 cuts. The edge at ② may cause the router to pull itself quickly into the template comb, so good router control is important.

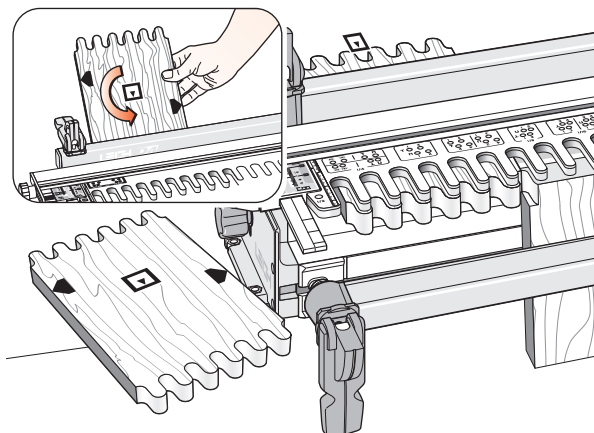
**7-15**

Rout both ends of both side boards, with inside faces ◻ away from the jig body.

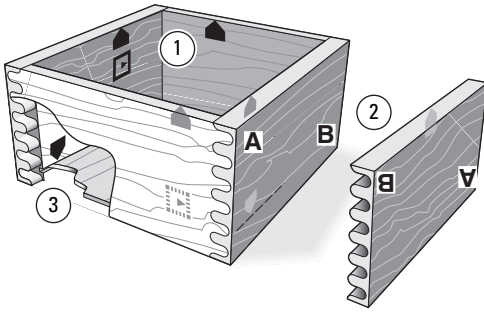

7-16

Rounded finger joint boards must be assembled with the inside faces inwards ① but unlike square box joints, the sides edges may be up or down ②. So you can decide on the preferred board orientation before marking and routing the box bottom grooves ③. You will probably need to clamp in both directions when gluing-up.

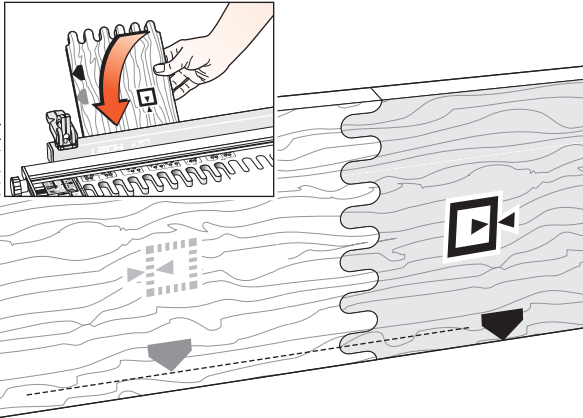

7-17 Rounded End-on-End Joints

These are routed exactly the same way as the box-side boards in the previous instruction, except that you must keep the same side edges against the side stop and alternate face side up/face side down ☐. Rout half the boards at the ☐ setting and the other half at the ☐ setting. ■

