

F2, F1600 APPENDIX III

Template Parts List



F2 & F2M PARTS LIST

For quick reference, record your
template's serial number here.

When ordering parts, please quote the Template model (inch or metric), serial number, part number, part description and quantity required.

PART NUMBER	QUANTITY PER TEMPLATE	PART DESCRIPTION
3001	1	"Inch" Template with decals
3001M	1	"Metric" Template with decals
3011	1	"Inch" Template Bar with glides (3140)
3011M	1	"Metric" Template Bar with glides (3140)
3020	1	Fence with brackets (3030)
3030	2	Fence Brackets
3040	1	RH Scale Bracket (RH in 1/2" & 1/4" mode) with screws (3110)
3050	1	LH Scale Bracket (LH in 1/2" & 1/4" mode) with screws (3110)
3060	1	RH Scale Assembly (RH in 1/2" & 1/4" mode) with screws (3110)
3060M	1	RH Scale Assembly (RH in 12mm mode) with screws (3110)
3070	1	LH Scale Assembly (LH in 1/2" & 1/4" mode) with screws (3110)
3070M	1	LH Scale Assembly (LH in 12mm mode) with screws (3110)
3080	2	Fence Knobs
3090	2	Fence Knob Bolts
3100	2	Fence Knob Wavy Washer
3110	4	Set Screws for Scale Bar and Bracket
3120	1	Template Pin with Tie (3130)
3130	1	Template Pin Tie
3140	4	Template Bar Glides
3149	1	F2 VGS Set complete, inch (contains 709V, 711V, 713V, 716V)
3149M	1	F2M VGS Set complete, metric (contains 711V, 713V, 716V)
3156	1	Allen Wrench for Set Screws
3157	1	VGS Box
3158	1	VGS Box Liner
3170	1	User Guide, combined inch & metric
700V	1	VGS Holder (2 pieces)
701V	1	VGS Holder
709V	1	VGS Bush for 1/4" Comb - for "Inch" template only
711V	1	VGS Bush for 5/16"[8mm] Comb
713V	1	VGS Bush for 3/8"[10mm] Comb
716V	1	VGS Bush for 1/2"[12mm] Comb
730V	1	Pin Wrench for VGS
741V	8	Nylon Thread-Inserts for VGS (on tree)

F2 & F2M PARTS ILLUSTRATION

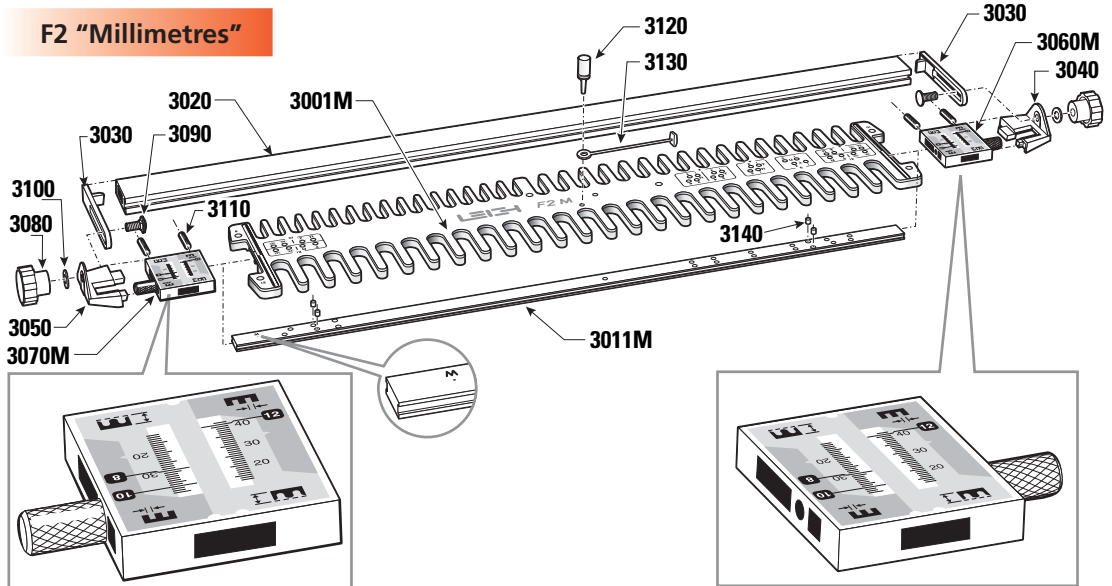
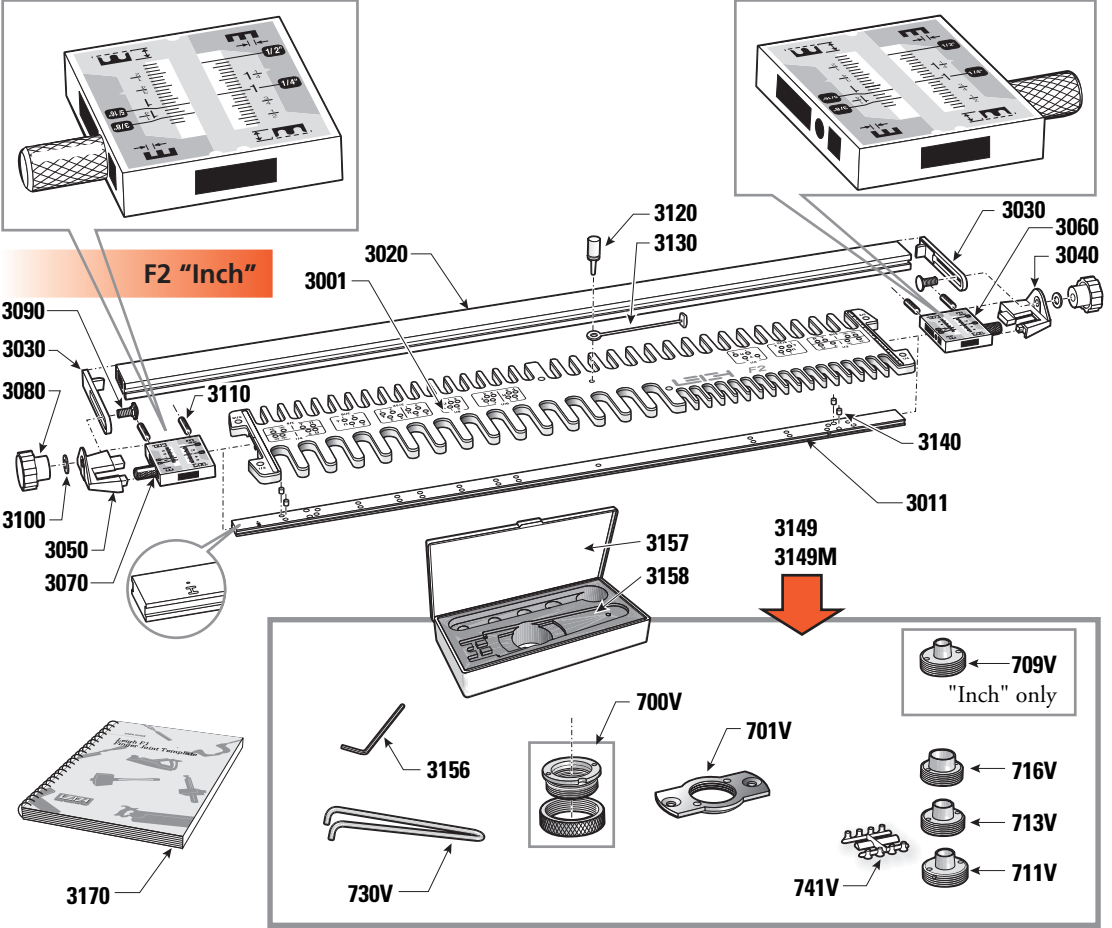

F1600 & F1600M PARTS LIST

For quick reference, record your
template's serial number here.

When ordering parts, please quote the Template model (inch or metric), serial number, part number, part description and quantity required.

PART NUMBER	QUANTITY PER TEMPLATE	PART DESCRIPTION
3300	1	"Inch" Template with decals
3300M	1	"Metric" Template with decals
3310	1	"Inch" Template Bar with glides (3140)
3310M	1	"Metric" Template Bar with glides (3140)
3360	1	RH Scale Assembly (RH in 1/4" & 8mm mode)
3370	1	LH Scale Assembly (LH in 1/4" & 8mm mode)
3120	1	Template Pin with Tie (3130)
3130	1	Template Pin Tie
3140	4	Template Bar Glides
3316	1	F1600 VGS Set complete, inch (contains 709V, 713V, 716V)
3149M	1	F1600M VGS Set complete, metric (contains 711V, 713V, 716V)
3157	1	VGS Box
3158	1	VGS Box Liner
3170	1	User Guide, combined inch & metric
7210	2	Scale Nut
7215	2	Scale Washer
7220	2	Scale Wedge
7225	2	Scale Lock Screw #8-32
7250	2	Scale Thumbscrew
7255	2	Nylon Flat Washer 1 ³ / ₆₄ " x 7/ ₁₆ " x .062"
700V	1	VGS Holder (2 pieces)
701V	1	VGS Holder
709V	1	VGS Bush for 1/4" Comb - for "Inch" template only
711V	1	VGS Bush for 8mm Comb - for "metric" template only
713V	1	VGS Bush for 3/8"[10mm] Comb
716V	1	VGS Bush for 1/2"[12mm] Comb
730V	1	Pin Wrench for VGS
741V	8	Nylon Thread-Inserts for VGS (on tree)

F1600 & F1600M PARTS ILLUSTRATION

F1600 "Inch"

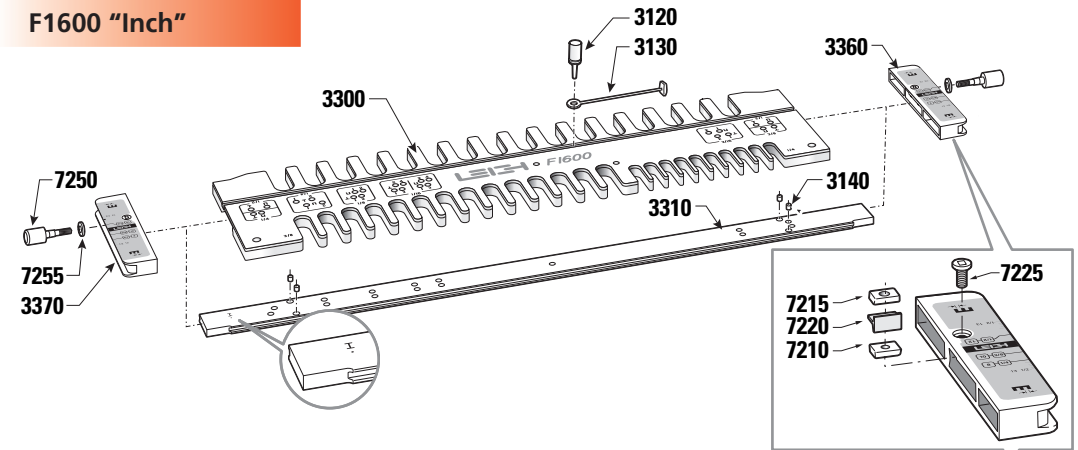

F1600M "Millimetres"

