

SUPERJIG - CHAPTER 7

Router Preparation

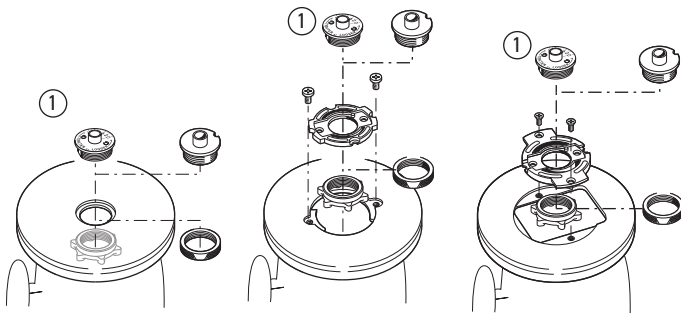

7-1 Fit the e7-Bush ①. One is included with your Super Jig. Some guidebush adaptors may have to be modified to allow adjustment rotation of the e7-Bush in the base. *See page 67.* If the e-Bush is incompatible with your router, any $\frac{7}{16}$ " [11,1mm] guidebush (min. depth $\frac{1}{4}$ " see page 67) will work for all but box joints on the Superjig.

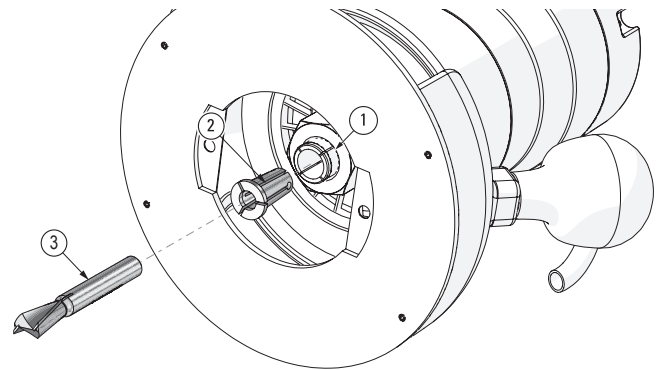

7-2 Routers used on Super Jigs must have a $\frac{1}{2}$ " or 8mm collet ①. All Super Jig bits have 8mm shanks. Routers with $\frac{1}{2}$ " collets must use the $\frac{1}{2}$ " to 8mm collet reducer ② supplied with the jig. The collet reducer ② is inserted in the router collet ① (chuck) and the 8mm shank bit ③ is inserted in the collet reducer. Routers with 8mm collets do not require a collet reducer.

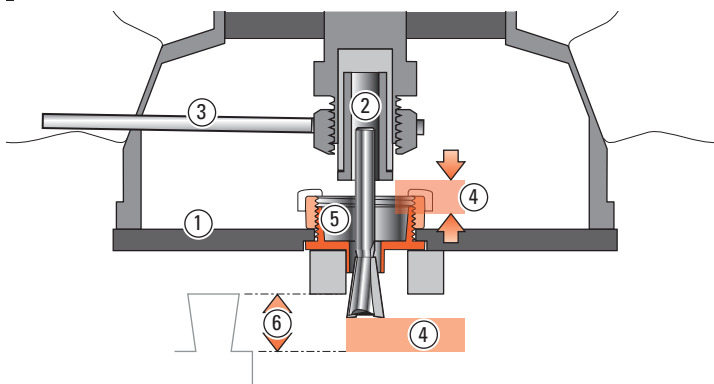

7-3 When fitting a bit to the router ①, fit the shank as far into the collet ② as possible. Always rout with the collet as close to the guidebush as possible. Usually you can't securely grip the collet nut with a wrench ③ if the collet is at its optimum low position. Fit the bit so that the remaining travel ④ between collet and guidebush ⑤ will let the bit reach the required depth of cut ⑥.

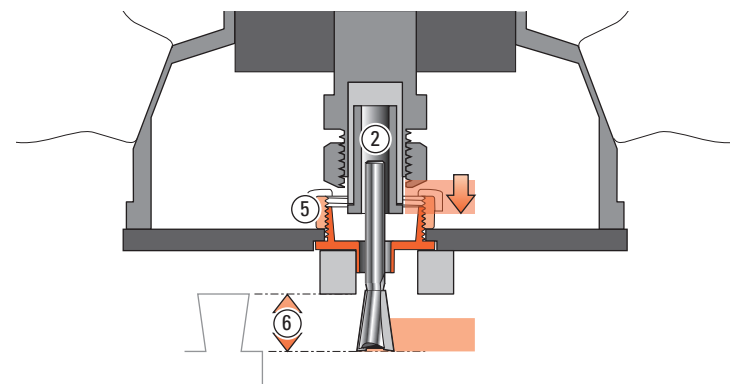

7-4 Tighten the collet ② securely and lower the collet to adjust the depth of cut ⑥, but make sure the collet does not contact the guidebush ⑤.

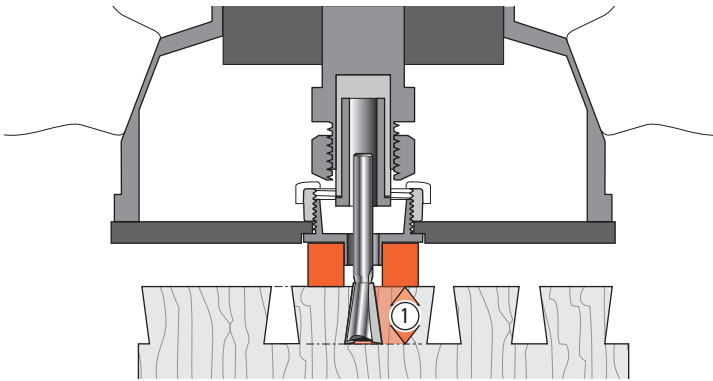

7-5 Depth of Cut: The depth of cut always refers to the actual depth of the cut into the wood beneath the guidefingers ①.

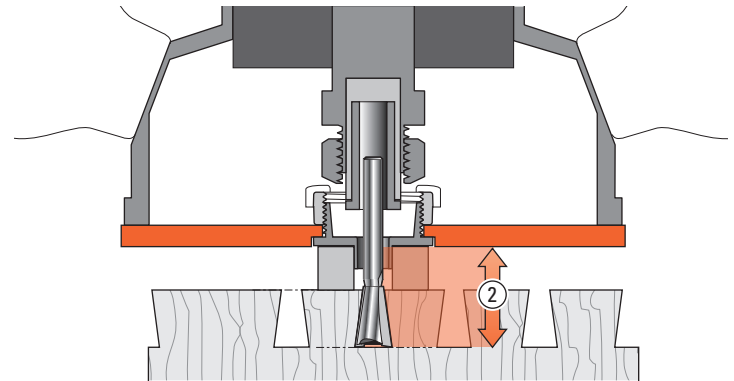

7-6 Depth of cut is **not** the distance the bit projects from the router base. This is **bit projection** ②. This user guide generally refers to depth of cut. Bit projection ② is always .500" [12,7mm] more than depth of cut.

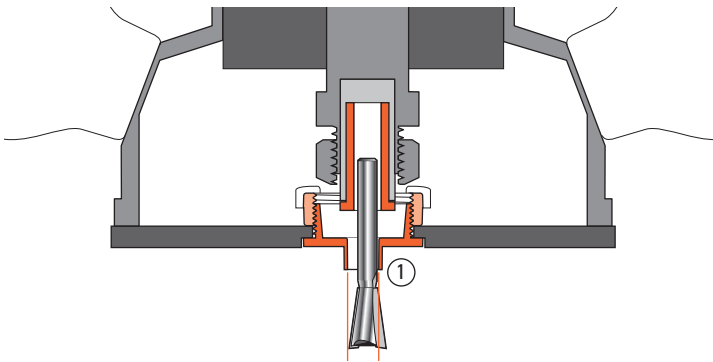

7-7 Ideally, the router collet (and bit) should be concentric (centered) to the guidebush as in figure 7-5. Regrettably, this is often not the case; the bit can be off center (eccentric to) the guidebush ①. The illustration shows the problem highly exaggerated. The good news: bit to bush alignment doesn't affect joint fit or flushness; both are "adjusted out" in normal jig setup.

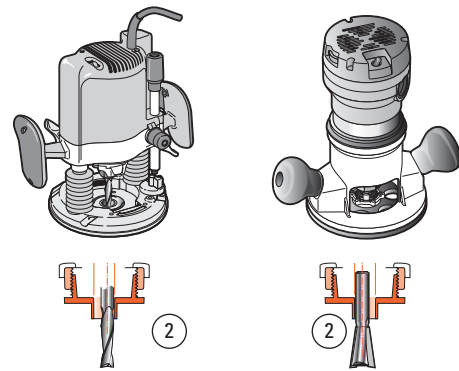

7-8 Bit to guidebush offset may change when the router motor is unclamped from the base when changing bits or making bit height adjustments. Concentricity problems can also arise if two routers are used for through dovetails, (one for pins; one for tails). Routers with different bit to guidebush offsets ② (misalignment shown highly exaggerated)...

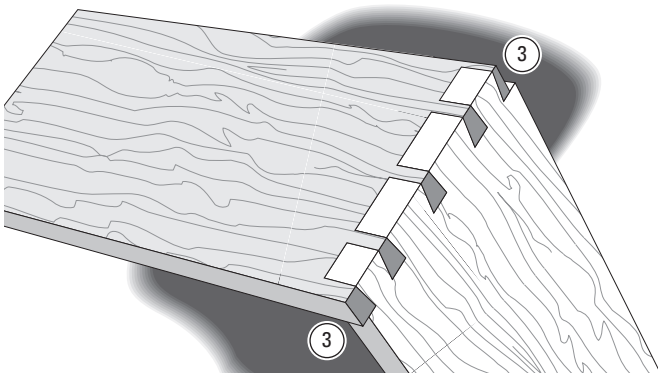

7-9 ...will cause pin to tailboard ③ misalignment (again, shown highly exaggerated).

Fortunately, some newer routers have sub-bases that can adjust for concentricity. If you don't have this type, it might pay to stick to a single router for through dovetails. ■