

SUPERJIG - CHAPTER 6

Wood Preparation

"Garbage In - Garbage Out"...

This adage of the computer age stands equally true for dovetail jigs.

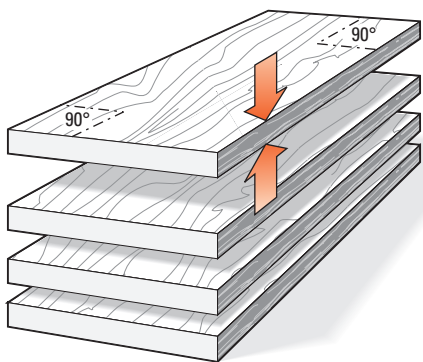

6-1 It is vital for accurately aligned joints that stock used on the Superjig should be prepared straight, flat, of even thickness and equal widths, with square ends and edges. *Note that plywood is generally unsuitable for routing because of tearout problems.*

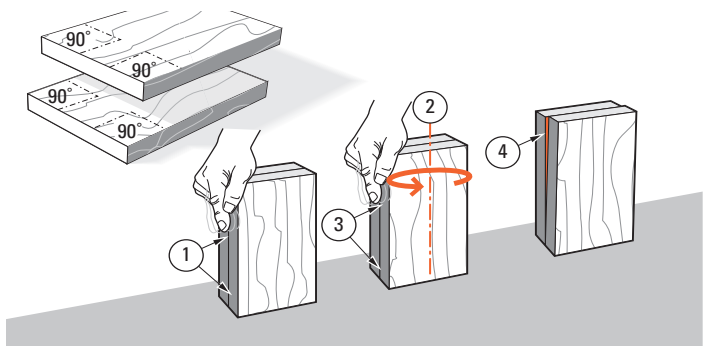

6-2 ⚠️ Check for squareness: stand both pieces vertically on a flat surface. Make sure side edges are flush at bottom and top ①. Turn one piece around on its end ②. If side edges are flush top to bottom ③, the boards are square. If not, ④; cut two that are.

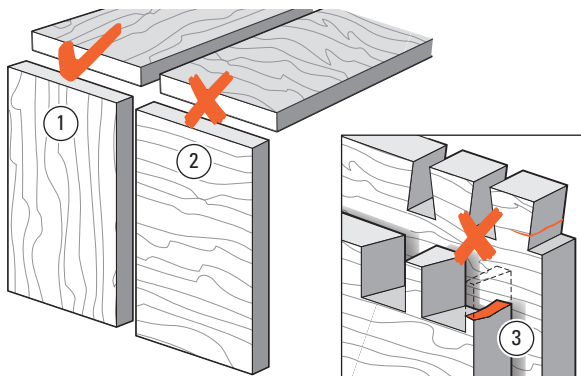

6-3 ⚠️ Dovetail joints are intended for joining end-grain to end-grain ①. Attempting to rout dovetails in side grain ② will not work because:

- A. The wood will tear out badly when routing.
- B. The pins and tails will easily break off across the short grain ③, either during or soon after assembly, when the boards start expanding and contracting at different rates.

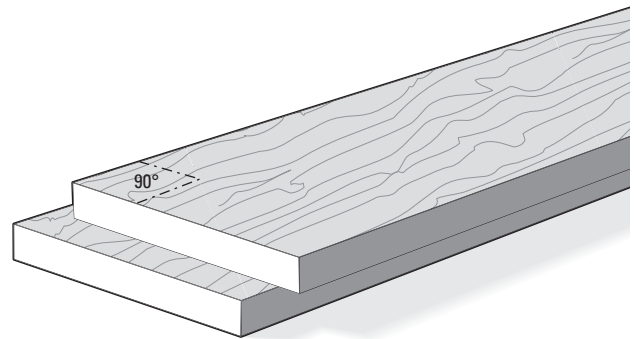

6-4 You will want to test the jig, so prepare some $\frac{3}{4}$ " x $5\frac{1}{2}$ " [20x140mm] boards. Cut them to length as you need them for the jig tests you want to perform. Use them for practice with the jig's various joint modes so you can see how the different modes work. **Remember, though, that two boards of different thicknesses can be joined just as easily.**