

# **LEIGH BOX/FINGER JOINT TEMPLATES**

## **User Guide**

*F3, F18 and F24 Box/Finger Joint Templates  
for Use on Leigh D-Series & SuperJig Dovetail Jigs*

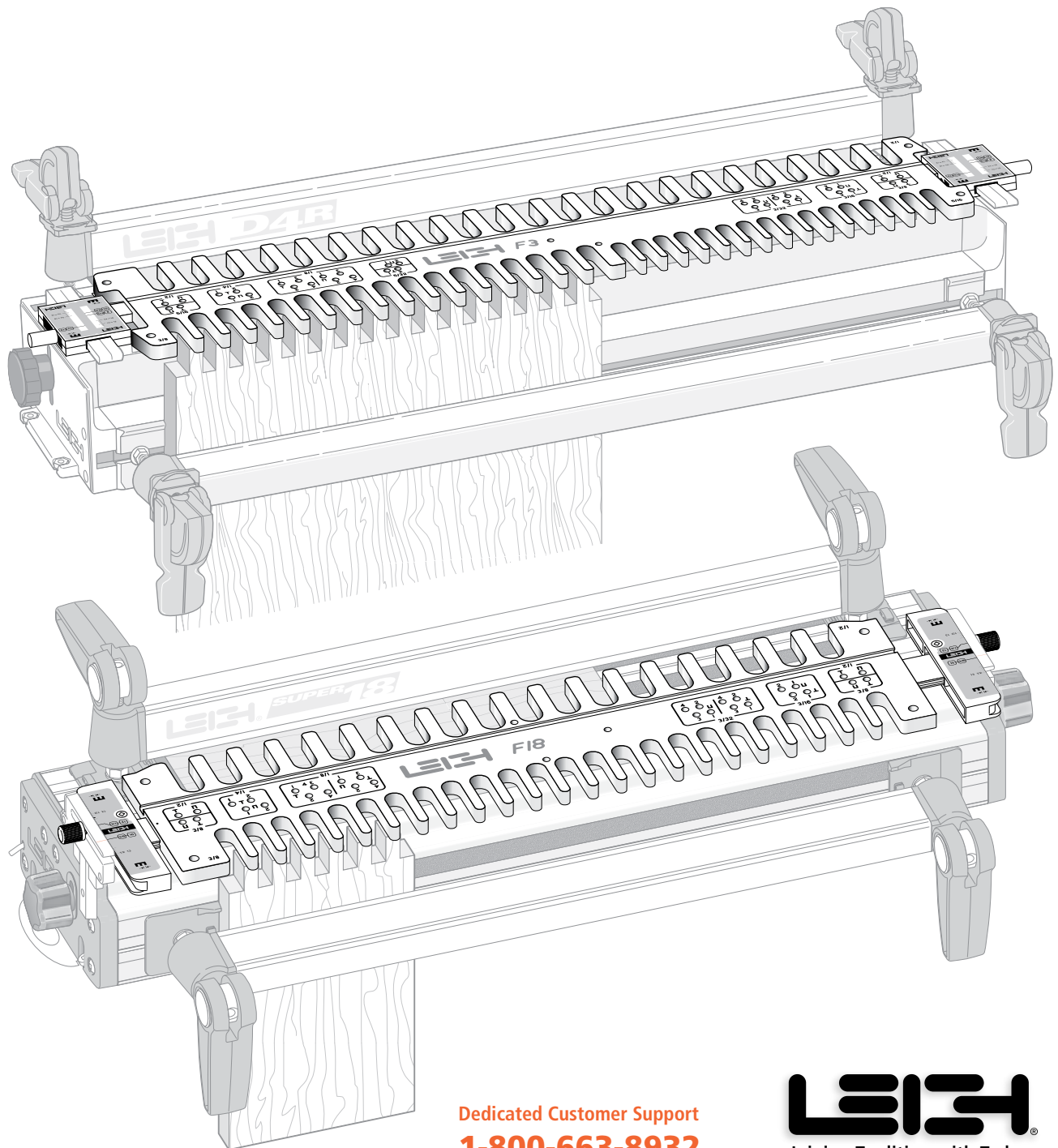

Dedicated Customer Support  
**1-800-663-8932**

**LEIGH**<sup>®</sup>  
Joining Tradition with Today

## Your new Leigh Finger Joint Template

You now own a superb finger jointing system. The Leigh Finger Joint template\* and adjustable e-Bush will help you rout finger or box joints with unique adjustment for precise tightness of fit.

“Finger” and “Box”: Both words are used universally to title this simple but strong joint. As the first machine-made joint, it’s old enough to be called antique, so we have been even-handed in using both terms throughout this guide.

We recommend that you first mount the template on your Leigh Jig, carefully following the instructions in the first section of the user guide. Then before you try to do any actual joinery routing, read the rest of the guide, following along with the basic functions. By all means, cut a few practice joints in scrap boards before you use the template to rout a precious hardwood workpiece.

If you have any questions that are not answered in this user guide, please call Leigh international customer support: 1-800-663-8932  
or email: [help@leighjigs.com](mailto:help@leighjigs.com).

For support contacts in your country of purchase see Appendix IV – Customer Support.

\* US Patent No. 5,711,356

Canadian Patent No. 2,146,834

European Patent No. 0698458

### LEIGH FINGER (BOX) JOINT SIZES

Inch Templates	Full Size (Inches)			Half Size (Inches)			Quarter Size (Inches)		Half-Blind (Inches)			Double Sizes (Inches)		
	<b>F3</b>	5/16	3/8	1/2	5/32	3/16	1/4	3/32	1/8	5/16	3/8	1/2	5/8	3/4
<b>F18</b>		3/8	1/2		3/16	1/4	3/32	1/8		3/8	1/2		3/4	1
<b>F24</b>		3/8	1/2		3/16	1/4	3/32	1/8		3/8	1/2		3/4	1
Metric Templates	Full Size (mm)			Half Size (mm)			Quarter Size (mm)		Half-Blind (mm)			Double Sizes (mm)		
	<b>F3M</b>	8	10	12	4		6	2		8	10	12	16	20
<b>F18M</b>		10	12		5	6		3		10	12		20	24
<b>F24M</b>		10	12		5	6		3		10	12		20	24

INTRODUCTION..... ii

Chapter 1 – Assembly, Mounting, and Template Alignment..... 1

Chapter 2 – Using Your Template Safely..... 5

Chapter 3 – Operation Concept and Basic Template Functions..... 7

Chapter 4 – The Leigh e-Bush Guide Bushing..... 9

Chapter 5 – Board Width Selection ..... 11

Chapter 6 – Box Joint Procedures..... 13

Chapter 7 – Half-Blind Box Joint Procedures ..... 17

Chapter 8 – Half, Quarter, and Double Size Box Joints ..... 19

Chapter 9 – Hints and Tips ..... 25

Appendix I – Attaching the Leigh e-Bush to the Router ..... 27

Appendix II – Bit Selection and Joint Specification..... 29

Appendix III – Template Parts..... 31

Appendix IV – Customer Support..... 35

**Are there operational differences between the F3 and F18/24?**

No. While the F18 and F24 are illustrated for most of the procedures in this guide, the differences between the F3 and the F18/24 do not affect the operational instructions. Movements and settings

illustrated in each step are identical whether performed on the F3/F3M, F18/24, or F18M/24M. Icon types for template pin positions are the same on all templates.

**F18/F18M**

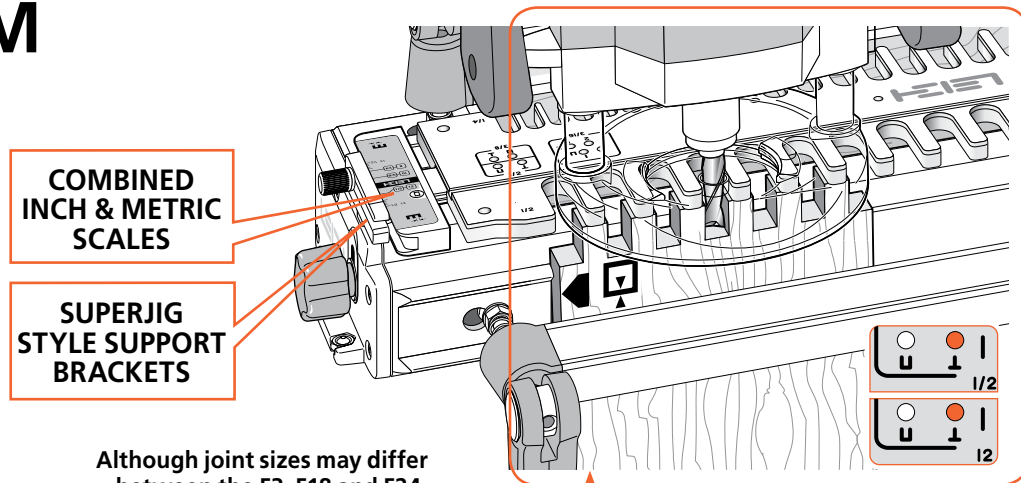

Although joint sizes may differ between the F3, F18 and F24, everything in these frames is operationally identical

**F3/F3M**

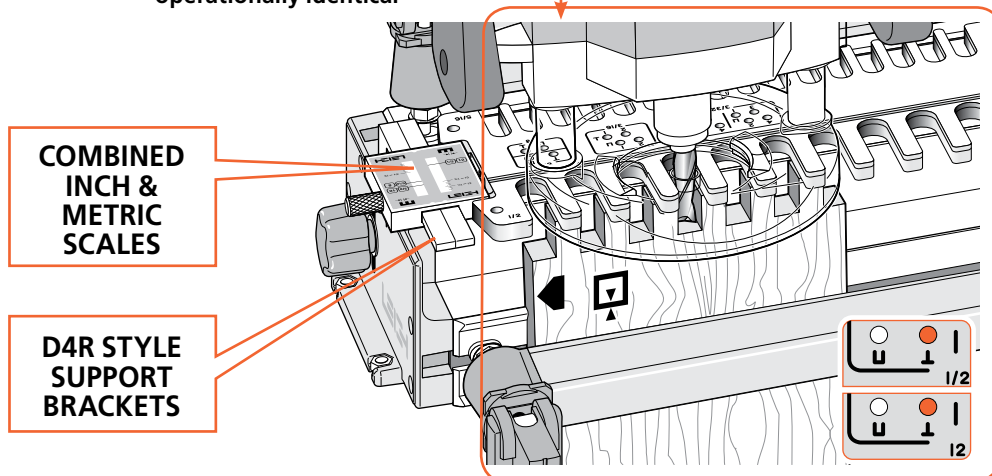

### Important: Inches and Millimeters

Because Leigh makes F3, F18 and F24 Templates in inch and metric models, measurements in this user guide are shown in both inches and millimeters. Dimensions are indicated with "inches" first, followed by "millimeters" in square parentheses.

Example:  $\frac{1}{2}$ " [12mm], or  $\frac{3}{4}$ " x  $5\frac{1}{2}$ " x 8" [20x140x200mm].

Do not be concerned if the inch/millimeter equivalents are not always exact. Just use the dimensions which apply to your jig.

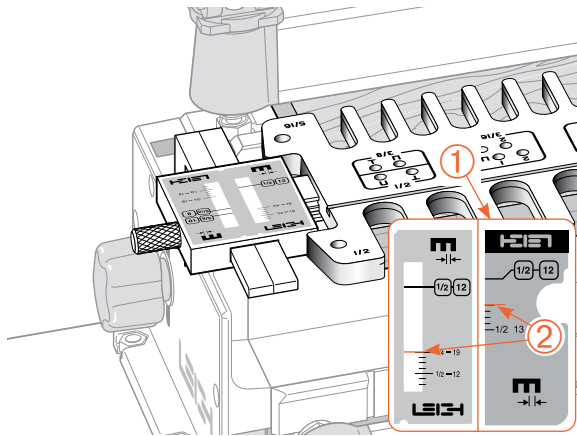

### Reading the Settings Illustrations

The F Template scales have dual markings for inch and metric.

*Note: The scales on some templates may indicate a  $\frac{1}{4}$ " [6mm] size. This comb size is only available on F1600 Templates.*

The template scales are illustrated in a panel overlaying the main illustration ① when settings are specified in an instruction. The inactive (upside down) part of the scale is not shown in the illustration.

Scale settings for instructions are shown with a red line ②.

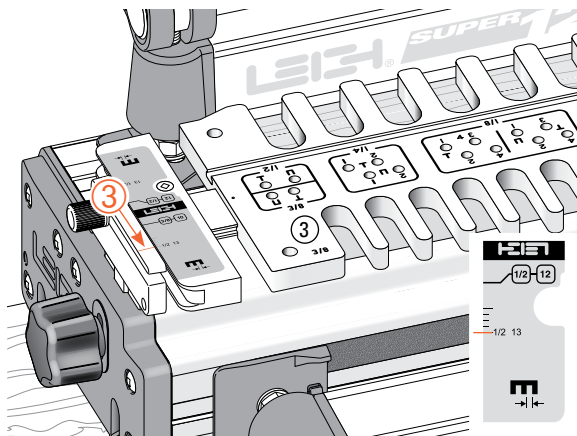

When calibration marks on the support brackets ③ are highlighted, they are illustrated in red for clarity. **On the jig, the lines are black.**

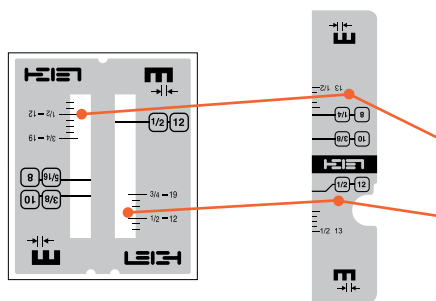

### Scale Icons

The Leigh Finger Joint Template has two modes. Position the selected comb to the front (toward you, the operator).

This places the  
Inactive scale upside down.  
and  
Active scale right side up.

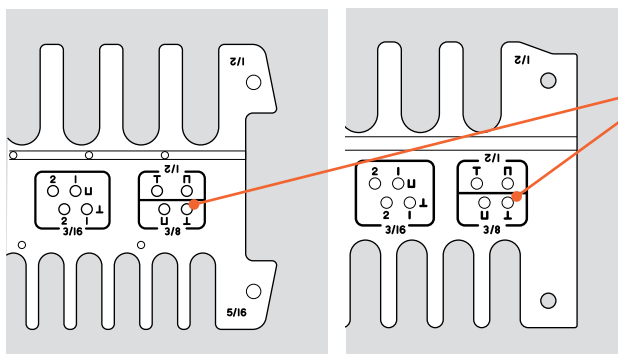



### Template Icons and Numbers (engraved)

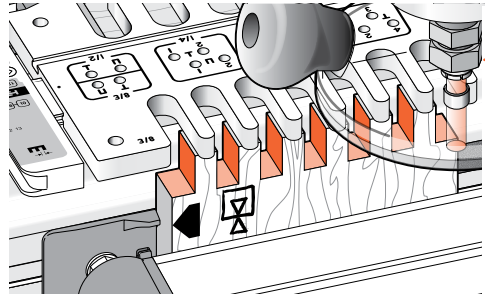

Template positioning holes (see page 7)

## Which Way Round Should the Board Go?

We devised these icons to indicate which side of a board faces out (toward you when it is clamped in the jig), and which faces are in or out when assembled.



 Boards are clamped in the jig both "face in" and "face out" for alternate end cuts; e.g. all regular box joint ends are routed this way

 Inside of board. All half-blind box joints are clamped in the jig with the inside  face away from the jig toward you, the operator.

 Shaded icons are on the other side of the board.

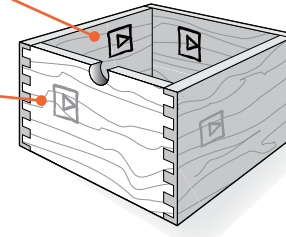
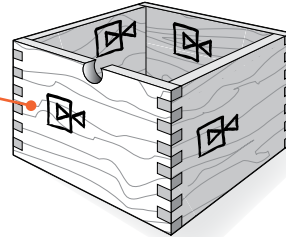



## How to Read the Symbols

To help you understand the instructions and illustrations in this user guide, we have used a number of international symbols, plus a few special ones of our own. They are all explained below. You needn't worry about memorizing these symbols now because they are repeated frequently throughout the guide, and you will soon get used to them.

### The following symbols indicate:

 This edge against side stop

 This edge against side stop

 As above, other side of board

 Caution: use special care for this operation

①②③ Numbered References in text

± Plus/Minus

= Equals

## Leigh Bit Sets make your jig even more versatile, and offer great savings and a free bit box!

Save over individual bit prices. Each top quality bit set includes a box with foam insert that accepts all shank sizes, and a handy bit chart in the lid to list out all the bit specs. Sets are available in either quality high speed steel or longer lasting solid carbide.

FOR THE  
**F3**

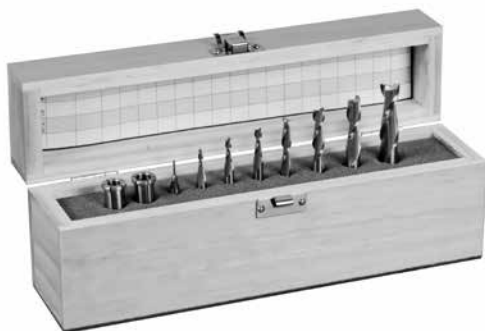

### **1608F High Speed Steel Boxed Bit Set, 10 pc**

Features 7 two-flute HSS spiral upcut bits and 1 single-flute (Bit 163). Set includes bits 163 (3/32"), 164 (1/8"), 165C (5/32"), 166 (3/16"), 168 (1/4"), 170 (5/16"), 173 (3/8"), 180 (1/2") and two collet reducers 172-8 (1/2" to 5/16") and 172-375 (1/2" to 3/8").

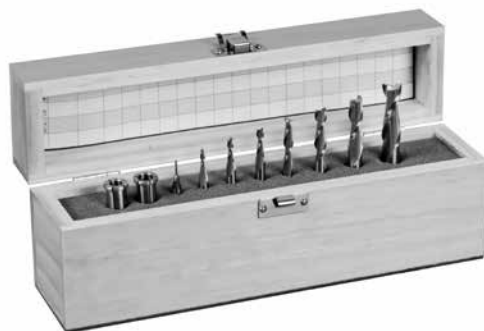

### **1608C Solid Carbide Boxed Bit Set, 10 pc**

Features 7 two-flute solid carbide spiral upcut bits and 1 single-flute HSS (Bit 163). Set includes bits 163 (3/32" HSS), 164C (1/8"), 165C (5/32"), 166C (3/16"), 168C (1/4"), 170C (5/16"), 173C (3/8"), 180C (1/2"), and two collet reducers 172-8 (1/2" to 5/16") and 172-375 (1/2" to 3/8").

FOR THE  
**F18/24**

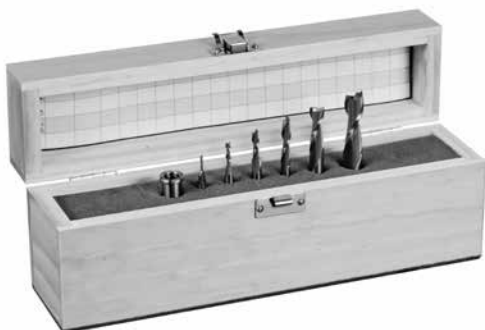

### **1806F High Speed Steel Boxed Bit Set, 7 pc**

Features 5 two-flute HSS spiral upcut bits and 1 single-flute (Bit 163). Set includes bits 163 (3/32"), 164 (1/8"), 166 (3/16"), 168 (1/4"), 173 (3/8"), 180 (1/2"), and collet reducer 172-375.

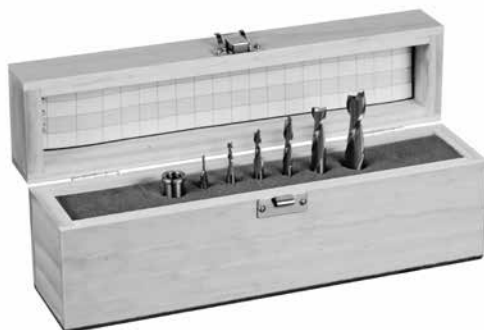

### **1806C Solid Carbide Boxed Bit Set, 7 pc**

Features 5 two-flute solid carbide spiral upcut bits and 1 single-flute HSS (Bit 163). Set includes bits 163 (3/32"), 164C (1/8"), 166C (3/16"), 168C (1/4"), 173C (3/8"), 180C (1/2"), and collet reducer 172-375.

## CHAPTER 1

# Assembly, Mounting and Template Alignment

## Assembly and Mounting

Before you begin mounting the Leigh Finger Joint Template to your Leigh Jig, make sure you have received the model ordered (Inch or Metric), and all the necessary parts.

1. 1 e7-Bush incl nut (F3 only)
  - 1 e8-Bush incl nut
  - 1 e10-Bush incl nut
  - 1 Pin Wrench
  - 1 User Guide
2. 1 Template “inch” assembly,  
or:
  - 1 Template “metric” assembly

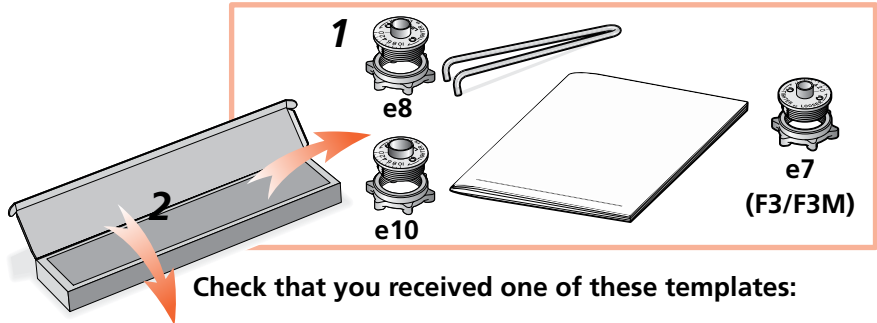

*If any of these items are missing, please notify your supplier or Leigh Industries immediately.*

Except for the scale thumbscrews (packed in a bag attached to the template), your Leigh F-Template comes fully assembled and requires only mounting and indexing to your Leigh jig. **This procedure is critical to the accuracy of the finished joinery**, so please follow the mounting instructions carefully.

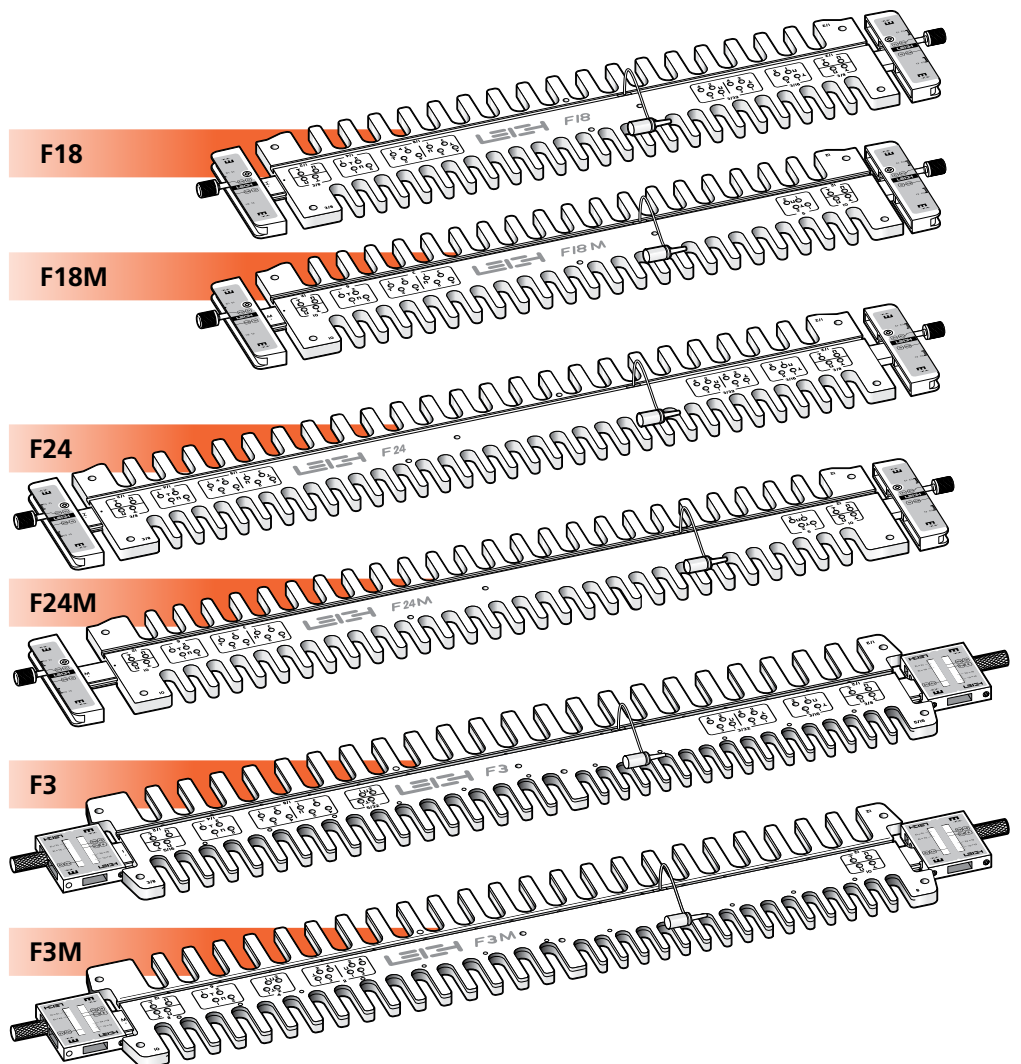

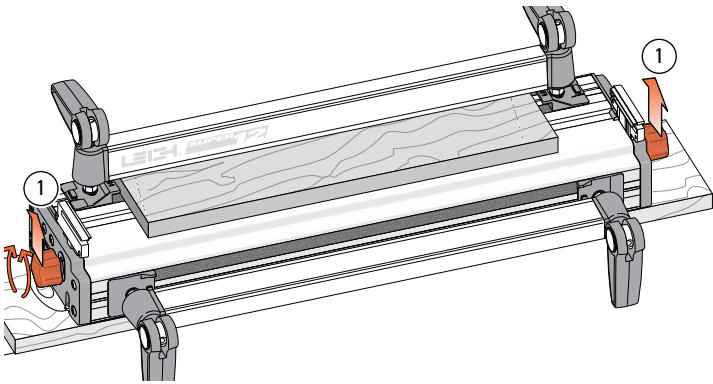

**1-1 Super18 & Super24 Jig Owners** D-Series jig owners go straight to 1-6.  
Raise both end support brackets and tighten the support bracket knobs ①.

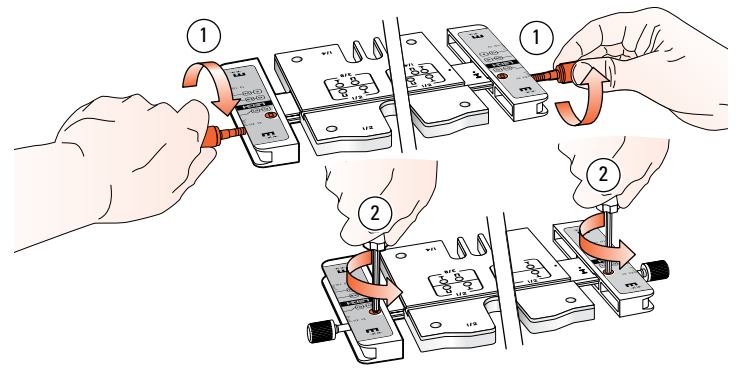

**1-2** Install the two thumbscrews a few turns into the scales ①. Loosen the scale lock screw ② at both ends (by one turn only).

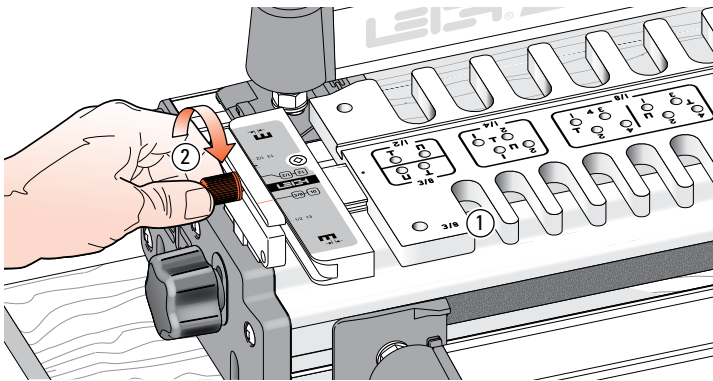

**1-3** Slide the template onto the support brackets, with the  $\frac{3}{8}$ " [10mm] comb toward you ① and set on the  $\frac{3}{8}$ " [10mm] setting. Tighten both thumbscrews ②. Do not lower the assembly onto the finger support board.

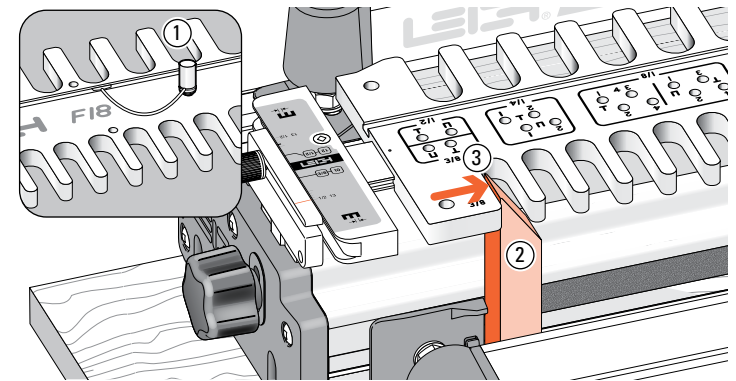

**1-4** Align the template so that its centre hole aligns with the hole in the bar and firmly insert the template pin ①. Angle trim the end of a straight block and clamp it tight against the left stop; the top protruding into the last  $\frac{3}{8}$ " [10mm] opening ②. Move the combined assembly to the right until the left side of the opening touches the block ③. Taking care to not move the template assembly...

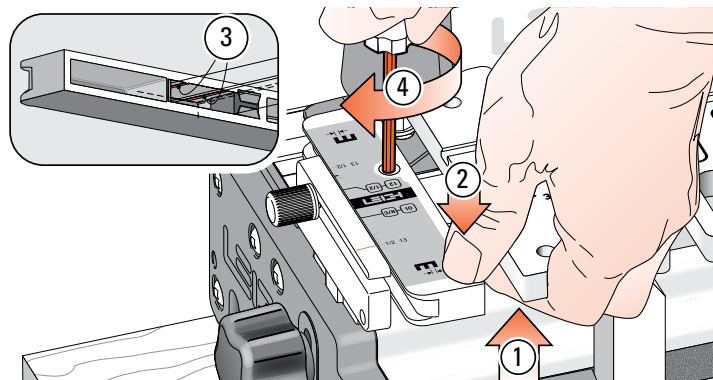

**1-5** ...pull up on the template bar ① while pushing down on the scale ② to ensure the bar is touching the two registration pads ③ inside the scale. Maintain pressure and tighten the scale lock-screw ④. Repeat at the other end. Remove the block and your template is ready to use. **To maintain correct template alignment, follow this procedure whenever you remove the scales from the finger assembly.**

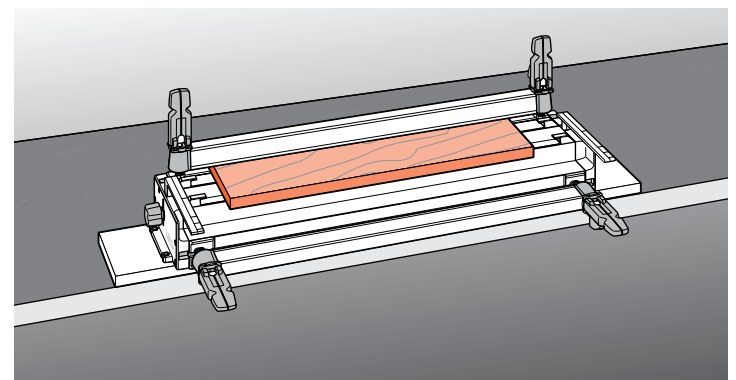

### 1-6 Mounting F3/F3M to D-Series Jigs

Procedure is the same for Inch and Metric 24" templates. Make sure your jig is mounted as per its User Guide, and the spacer board is clamped into position.



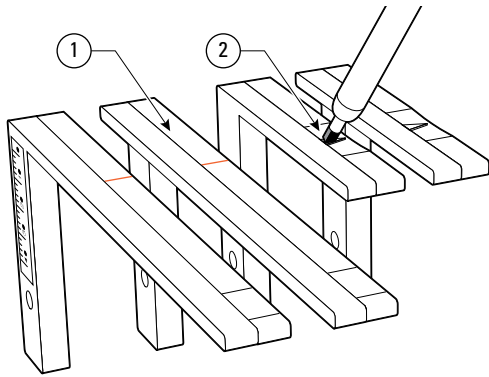

**1-7 D1258, D1258R and D3 jig owners:** If you already own the Leigh Mortise and Tenon Attachment, fit its extended support brackets ① and use for all finger joint and dovetail procedures. If not, mark the arrow pointers on the standard support brackets ② with a dark felt pen. Some D4 and D4R Jig owners already have extended brackets. Late model D4R brackets are shorter.

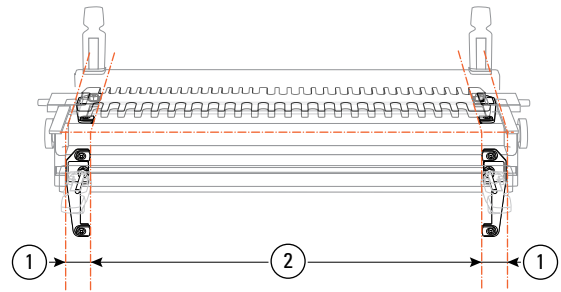

**1-8** Before installing the F3/F3M on any 24" D-series jig with adjustable side stops, set and index the stops according to the jig's user guide. Are the stops 1 1/2" [38mm] in from each end of the jig body extrusion ① and 24 1/8" [613mm] apart ②? If not, do it now.

*D4R jigs have fixed side stops.*

**Centering Template on Jig All 24" D-series jigs**

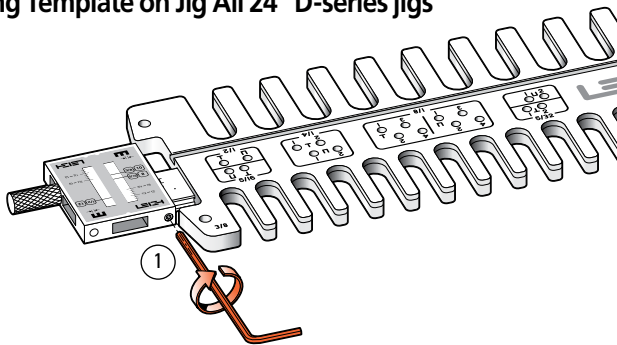

**1-9** Loosen the scale bar set screw ①, at each end of the template.

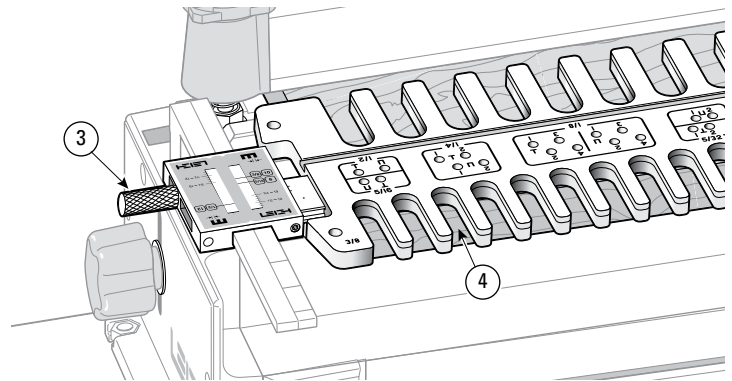

**1-10** Slide the template assembly onto the jig support brackets with the 3/8" & 5/16" [10 & 8 mm] combs toward you and lower it gently onto the jig's spacer board ④. Make sure the scale reading is the same on both scales, e.g. 1/2", then tighten the thumb screws ③.

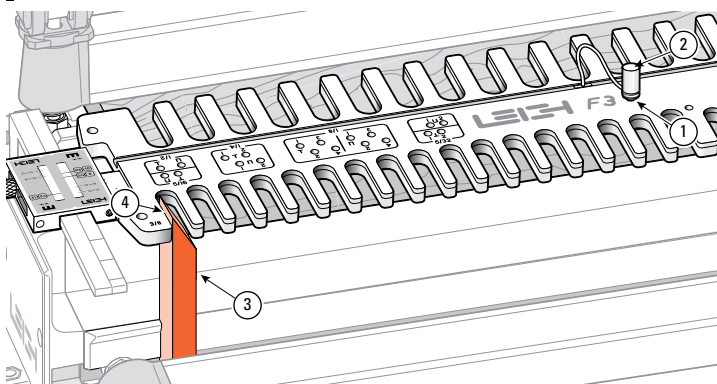

**1-11 Centering the F3** Align the template so that its center hole ① aligns with the hole in the bar. Insert the template pin ② with a gentle twist to seat it. Angle trim the end of a straight block; clamp tight against the left stop and into the first opening ③. Move the combined assembly so the left side of the opening touches the block ④. Taking care to not move the template assembly...

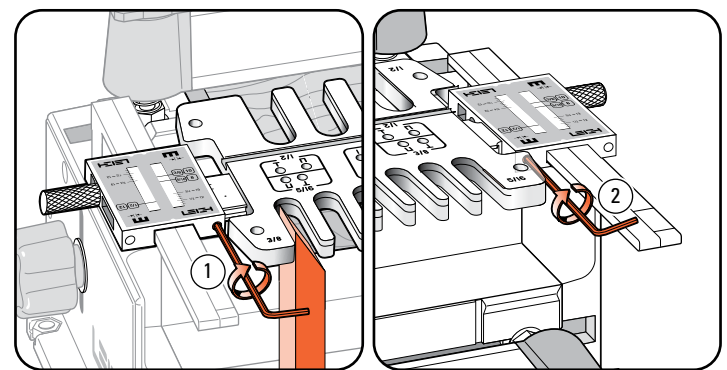

**1-12** ...tighten both scale set screws ① and ②. Remove the block and your Leigh F3 is ready to use. ■



## CHAPTER 2

## Using Your Template Safely

**Safety is not optional.**

Read and follow the recommendations in this chapter.

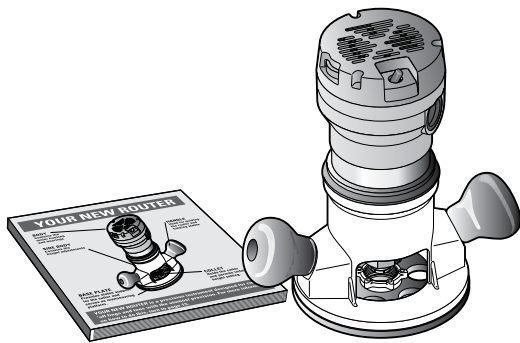

**2-1** Read the owner's manual that came with your router. It is essential to understand the router manufacturer's instructions completely.

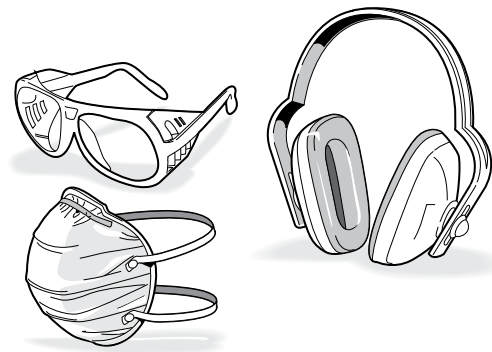

**2-2** Always wear approved safety glasses. Protect yourself from harmful dust with a face mask. Always wear hearing protection. For complete comfort and convenience, get yourself a Leigh VRS (Vacuum Router Support) to match your jig model.



**2-3**  Never drink alcohol or take medications that may cause drowsiness when you will be operating a router.

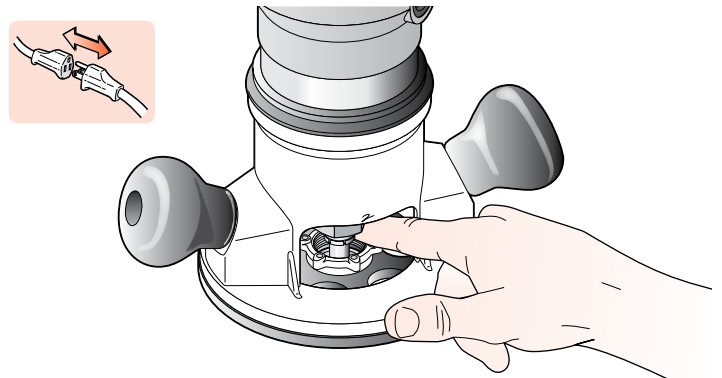

**2-4** Always disconnect the power source from the router when fitting bits or guidebushes, or making adjustments. Before connecting the router to the power source, make sure the bit and collet revolve freely in all the areas you plan to rout, and the bit does not touch the guidebush or jig.

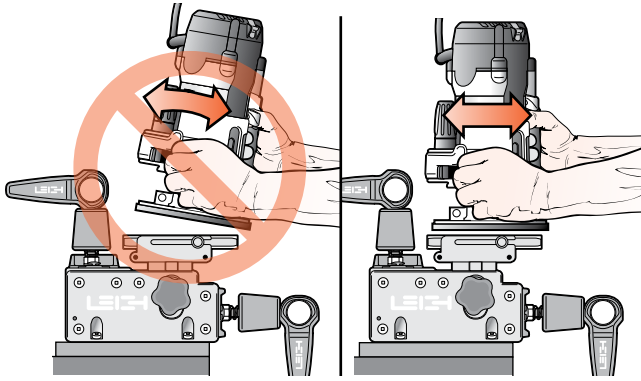

**2-5 Do not tilt the router on the jig.**  
Keep the router flat on the jig assembly.  
*Note: The optional Leigh VRS attachment prevents router tilting.*

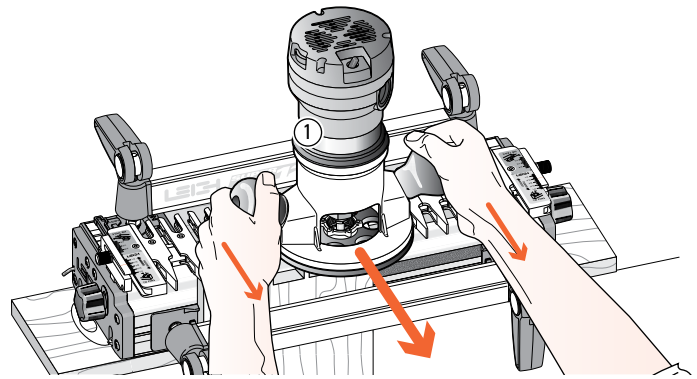

**2-6** If you insist on removing the router from the jig while it is still revolving, **always pull it straight off the jig horizontally**, and do not raise or lower the router until it is completely clear of the jig.

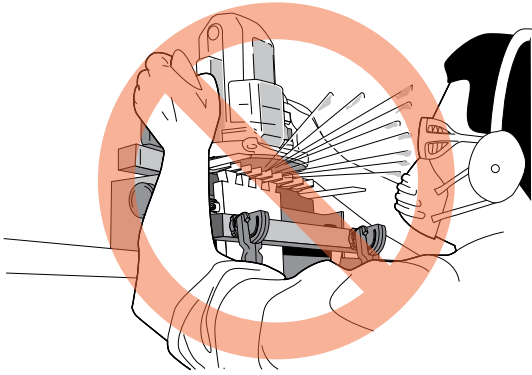

**2-7 Do not rout at face level.**

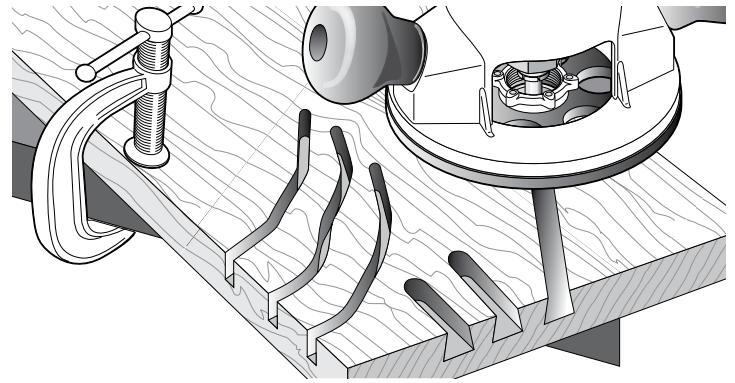

**2-8** If you have never used your router before, be sure to follow the router manufacturer's instructions for its use. Make plenty of simple open-face practice cuts *without a guidebush* before you try to use the router on the Leigh jig. You must, of course, always use a guidebush when routing on the Leigh Jig. ■

CHAPTER 3

# Operation Concept and Basic Template Functions

## Template Modes

Template pin hole icons denote the type of joint and edge finish from each position.

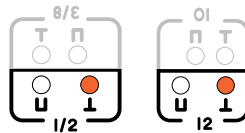
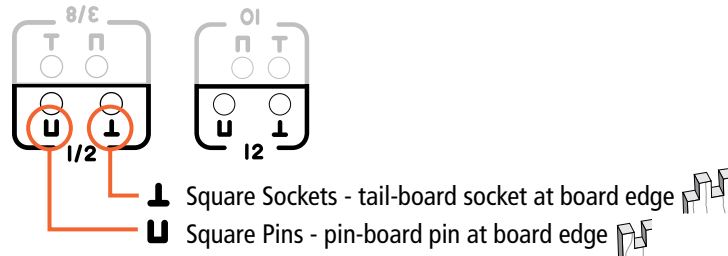

Throughout the manual, the proper pin location for each step is highlighted with red in an inset. Only the front (active) pinholes will be shown.

## Scale Modes

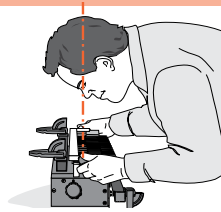

Reading scales from directly overhead improves setting accuracy.

## F3

The inactive scale is always on the left side of each scale assembly and is upside down.

The active scale is always on the right side of each scale assembly.

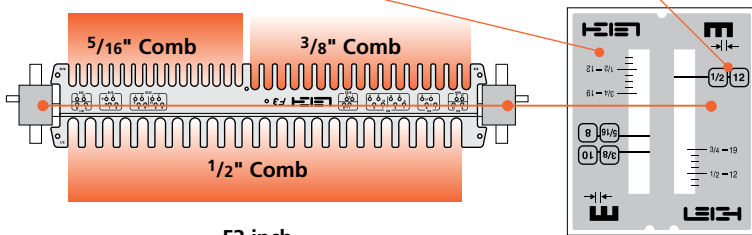

F3 inch

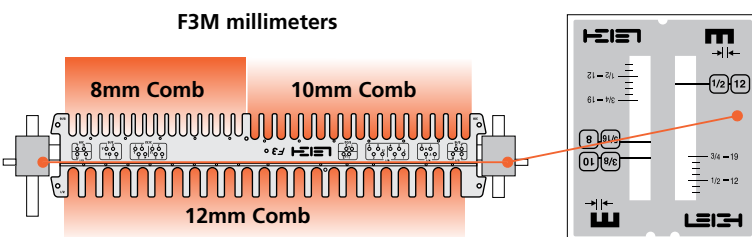

F3M millimeters

## F18 and F24

The inactive scale is always upside down.

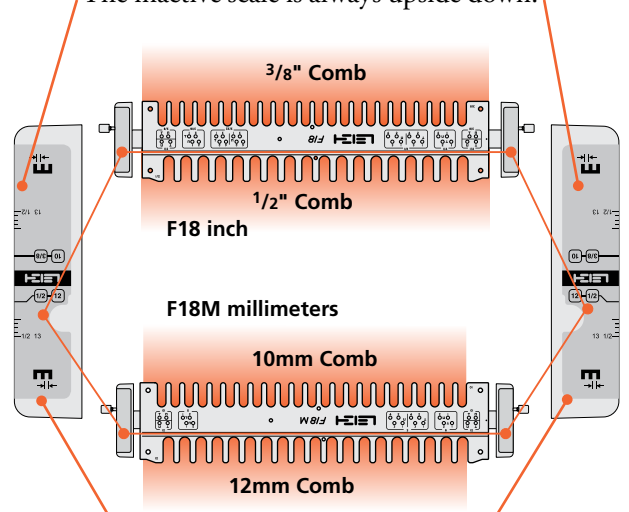

The active scale is always right side up and toward you.

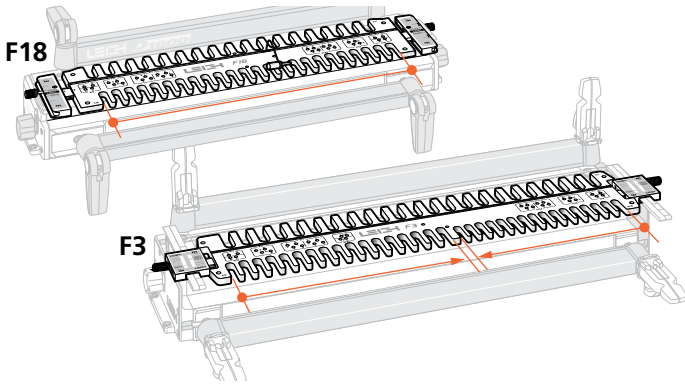

**3-1** The *active* comb (the one you wish to use) is positioned toward you at the front of the jig. Depending on the Template model and comb size selected, the active comb may start at either the right, or left-hand side of the jig. Combs that are the full width of the template always start at the left side.

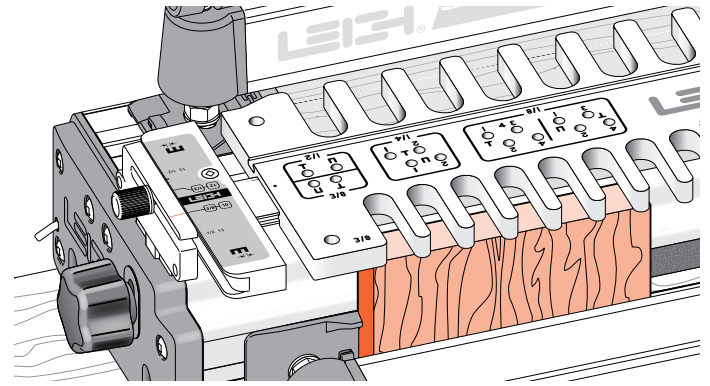

**3-2** Clamp your work pieces against the front side stop or...

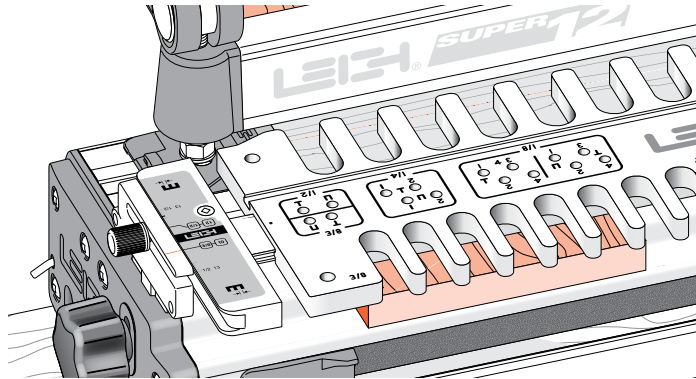

**3-3** ...the mating rear side stop, depending on which procedure is to be used.

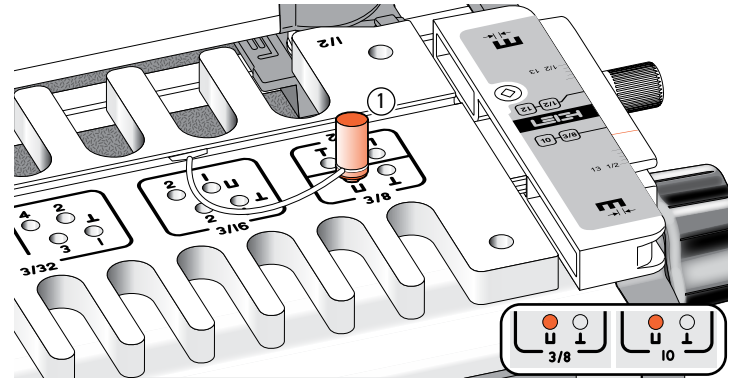

**3-4** The template control pin engages the template to the template bar using precisely positioned holes ①. The active template pin holes are always at the opposite end of the template, out of the way of the router. Most illustrations will have an inset showing the correct template pin hole position for the procedure.

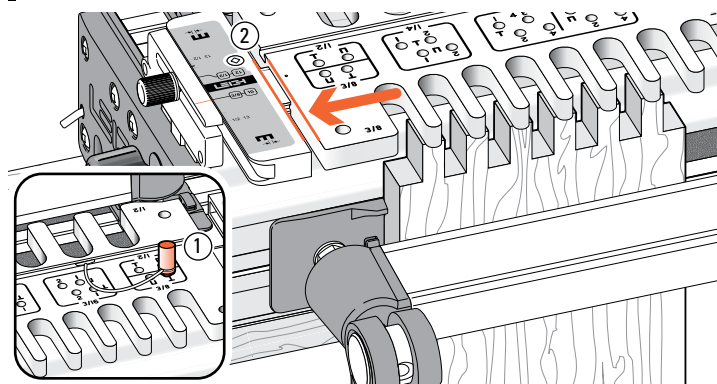

**3-5** Mating joints routed under the same comb have to be offset to achieve correct joint alignment. On Leigh templates the offset is achieved by moving the template left or right by half the pitch of the comb. This movement is controlled by the template pin, at the other end of the template ①. *Note that the template is close to the scale ②.*

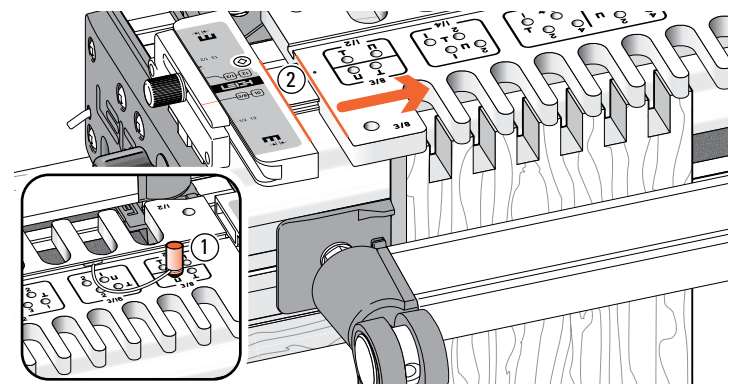

**3-6** In this illustration, the template is moved to the right by half the comb pitch and positioned by the template pin ① to rout the mating half of the joint in 3-5. *Note the increased gap between the scale and template ②.* ■

## CHAPTER 4

# The Leigh e-Bush Guide Bushing

The guidebush is the vital link between router and jig. Leigh's innovative e-Bushes\* provide precise fit adjustment for your router when using F3, F18 and F24 Templates.

\*e7, e8, and e10 e-Bushes are supplied with the F3 Finger Joint Template. e8 and e10 e-Bushes are supplied with each F18 and F24 Finger Joint Template. U.S. Patent No. 8,256,475. UK Patent No. GB2443974. Patent Pending in Canada.

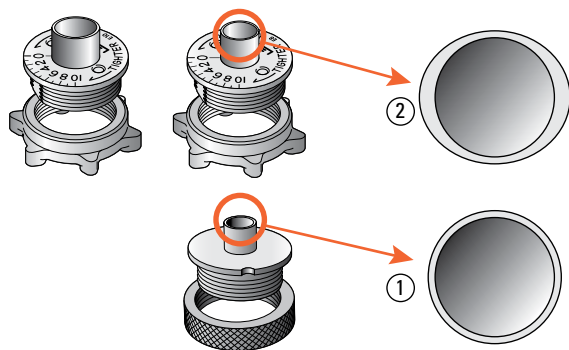

**4-1** Unlike plain circular template guidebushes ①, the e-Bush is elliptical ②. This innovation effectively changes the guidebush “active diameter” when it’s rotated, and provides benefits not possible with a plain round guidebush. The F18 and F24 Templates include two Leigh e-Bushes\*: e8 for  $\frac{3}{8}$ " [10mm] combs, and e10 for  $\frac{1}{2}$ " [12mm] comb; the F3 includes those plus the e7 for  $\frac{5}{16}$ " [8mm] comb.

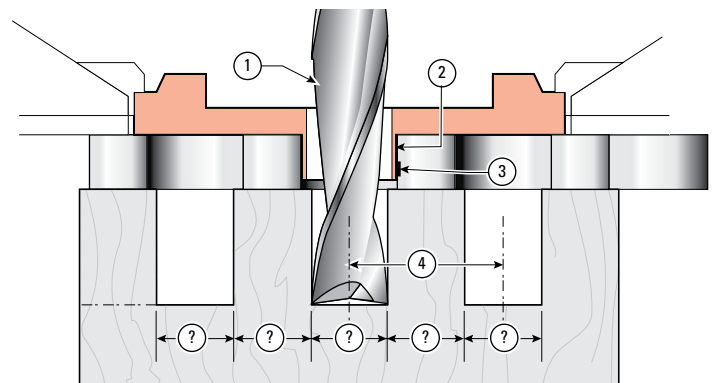

**4-2 Joint Fit and Joint Pitch** Box joints routed with standard sized straight bits ① and standard sized guidebushes ② against straight guide surfaces ③ on pitch centres exactly two times the bit diameter ④ will guarantee a loose fitting joint. Bits, guidebushes and templates are manufactured with necessary plus/minus tolerances and the router will have some degree of run-out, or “wobble”.

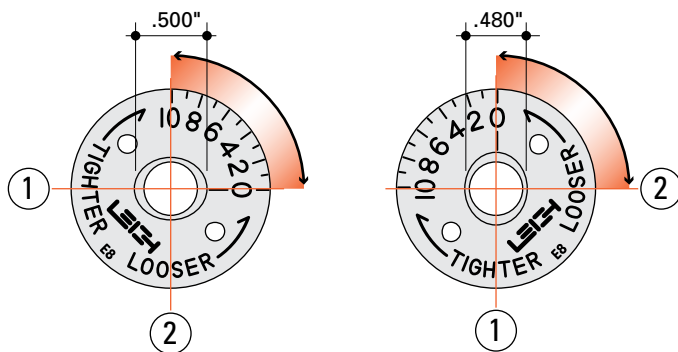

**4-3** The e-Bush (e8 illustrated) fits to the router base or to a guidebush adaptor in the base. See Appendix I. The ellipse or oval shape major axis ① is  $\sim .500$ " , and minor axis ②  $\sim .480$ " [12,7 x 12,2mm]. Turning the e-Bush 90 degrees in the router base changes the active guide size by  $.020$ " [50mm] providing infinite adjustment and recordable settings for perfectly fitting box joints.

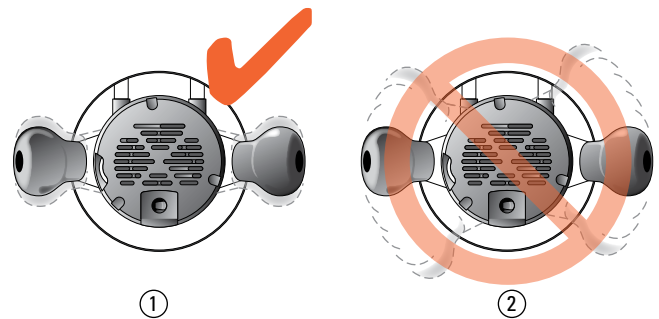

**4-4** Here's how it works. In normal use, the operator does not rotate the router more than a few degrees either way ①. In fact, because of potential bit-to-bush eccentricity problems it is advisable to minimize router rotation on jigs ②.

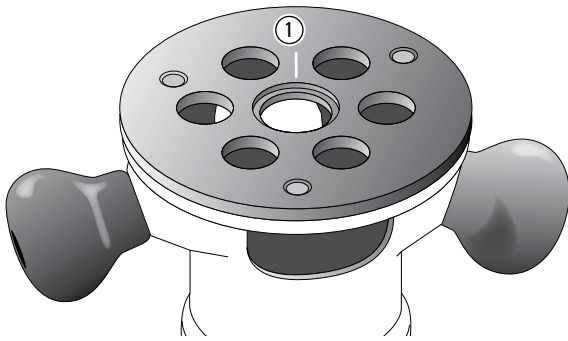

**4-5** Establish the orientation in which you normally hold and operate the router on the jig. Now, up-end the router in the same orientation. Make a small scratch line or permanent ink mark on the router base or e-Bush adaptor at the 12 o'clock position ①.

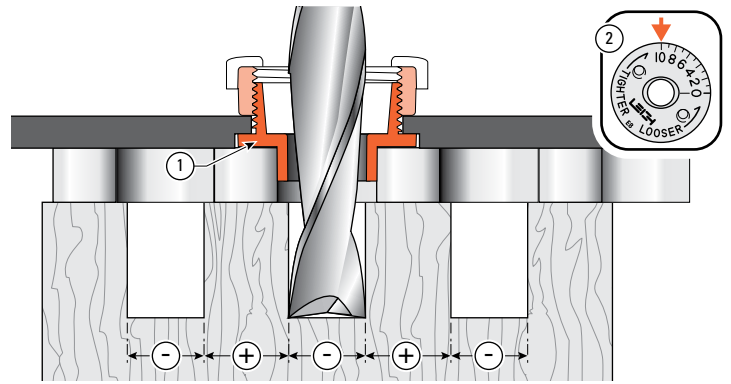

**4-6** With the e-Bush ① turned to “10” in the base ② the active “diameter” is increased, allowing less side-to-side movement, and resulting in smaller sockets and larger pins. A tight fit! *Scale and movement are exaggerated in this sequence of illustrations.*

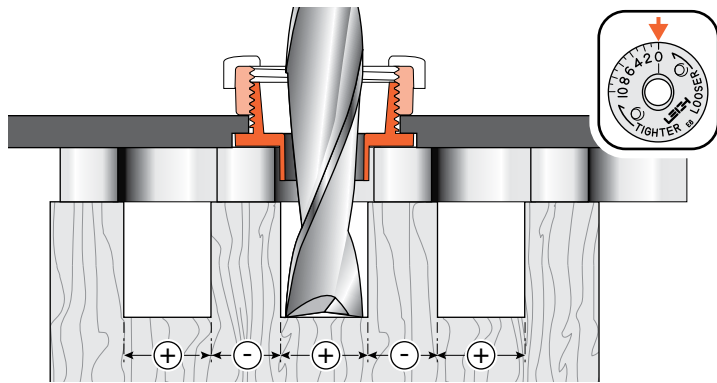

**4-7** Turning the e-Bush to zero allows more side-to-side router/bit movement, and more wood removal, producing larger sockets and smaller pins, and thus a loose fit.

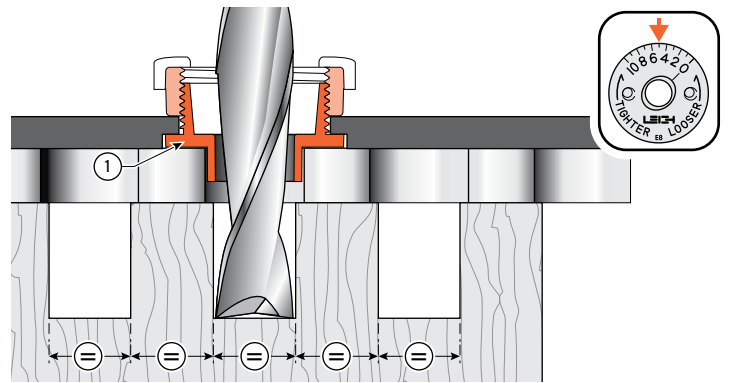

**4-8** A few trial-and-error test cuts and e-Bush adjustments will allow you to establish the correct pin and socket sizes for a perfect fit. **Note:** One division of the e-Bush changes the joint glue-line interface by two thousandths of an inch, that is, 0.002" or 0,050mm.

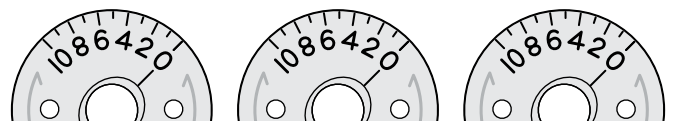
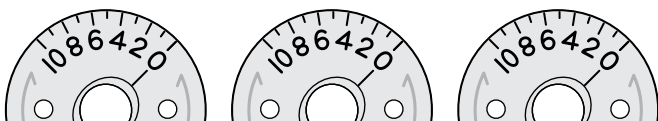
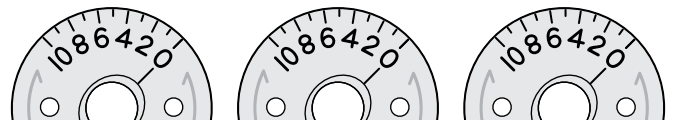
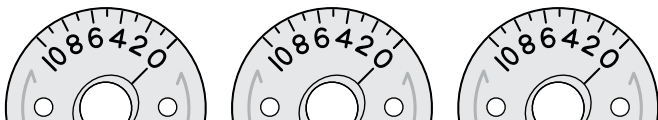

**4-9** When you have the best joint fit, mark the setting in pencil here. Different wood hardness may require slightly different settings, so also note the wood species. Use the same bit next time. ■



## CHAPTER 5

## Board Width Selection

Board widths are determined by the number of fingers you want in your design and whether the joint is symmetrical or asymmetrical. This chapter makes it easy to determine appropriate widths for the Leigh Finger Joint Templates.

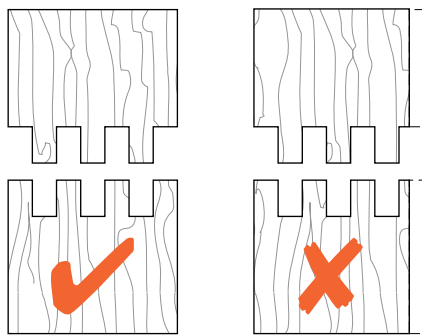

### 5-1 Board Widths and Joint Symmetry

Unlike the infinitely variable Leigh Dovetail Jig, a fixed template cannot accommodate any width of board and still produce a neat and even finish on both side edges of a joint. The boards must be cut to specific widths, depending on the pitch of the comb.

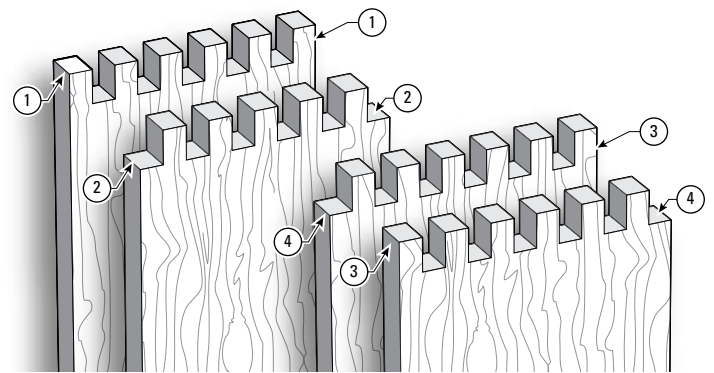

**5-2** Symmetrical joints have pins ① on both side edges of one board and sockets ② on both side edges of the mating board. Asymmetrical joints have a pin ③ on one side edge and a socket ④ on the other side edge of each board.

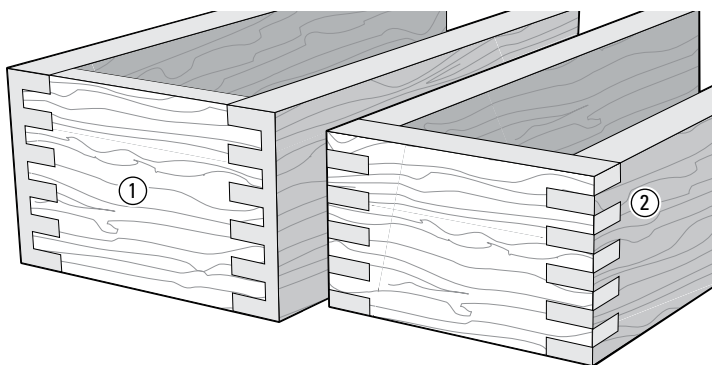

**5-3** Symmetrical joints are essential for half-blind corners ①. However, ordinary box joints may be asymmetrical and look okay ②.

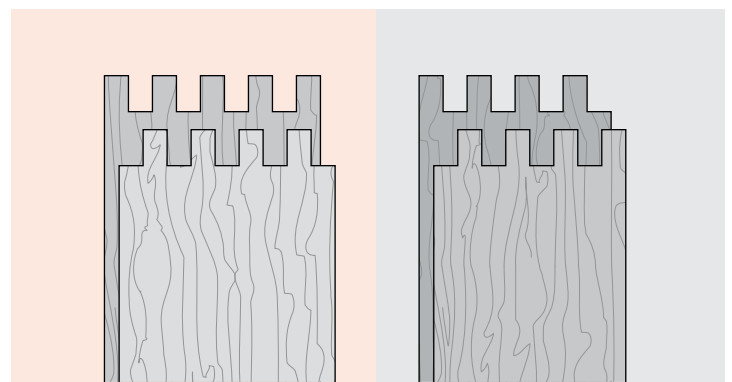

**5-4** ⚠ The comb pitches on the Leigh Finger Joint Templates are all 2 times the bit diameter plus  $\frac{1}{32}$ " [0,75mm], so you cannot simply use bit diameter to calculate board widths. See the board width charts on Page 12. For symmetrical square joints use board widths in red column. For asymmetrical square joints use widths in grey column.

Board Width - MILLIMETERS

Board Width - INCHES

JOINT SIZES

JOINT SIZES

	5/16"	5/8"	3/8"	3/4"	1/2"	1"	8	16	10	20	12	24
<b>Symmetrical</b>												
<b>Asymmetrical</b>												
<b>F3 Template</b>	1 2 3 4 5 6 7 8 9 10 11 12 13 14 15 16 17 18 19 20 21 22 23 24 25 26 27 28 29 30 31 32	1 2 3 4 5 6 7 8 9 10 11 12 13 14 15 16 17 18 19 20 21 22 23 24 25 26 27 28 29 30 31 32	1 2 3 4 5 6 7 8 9 10 11 12 13 14 15 16 17 18 19 20 21 22 23 24 25 26 27 28 29 30 31 32	1 2 3 4 5 6 7 8 9 10 11 12 13 14 15 16 17 18 19 20 21 22 23 24 25 26 27 28 29 30 31 32	1 2 3 4 5 6 7 8 9 10 11 12 13 14 15 16 17 18 19 20 21 22 23 24 25 26 27 28 29 30 31 32	1 2 3 4 5 6 7 8 9 10 11 12 13 14 15 16 17 18 19 20 21 22 23 24 25 26 27 28 29 30 31 32	1 2 3 4 5 6 7 8 9 10 11 12 13 14 15 16 17 18 19 20 21 22 23 24 25 26 27 28 29 30 31 32	1 2 3 4 5 6 7 8 9 10 11 12 13 14 15 16 17 18 19 20 21 22 23 24 25 26 27 28 29 30 31 32	1 2 3 4 5 6 7 8 9 10 11 12 13 14 15 16 17 18 19 20 21 22 23 24 25 26 27 28 29 30 31 32	1 2 3 4 5 6 7 8 9 10 11 12 13 14 15 16 17 18 19 20 21 22 23 24 25 26 27 28 29 30 31 32	1 2 3 4 5 6 7 8 9 10 11 12 13 14 15 16 17 18 19 20 21 22 23 24 25 26 27 28 29 30 31 32	1 2 3 4 5 6 7 8 9 10 11 12 13 14 15 16 17 18 19 20 21 22 23 24 25 26 27 28 29 30 31 32
<b>F18 Template</b>	34 35 36 37 38 39 40 41 42 43 44 45 46	34 35 36 37 38 39 40 41 42 43 44 45 46	34 35 36 37 38 39 40 41 42 43 44 45 46	34 35 36 37 38 39 40 41 42 43 44 45 46	34 35 36 37 38 39 40 41 42 43 44 45 46	34 35 36 37 38 39 40 41 42 43 44 45 46	34 35 36 37 38 39 40 41 42 43 44 45 46	34 35 36 37 38 39 40 41 42 43 44 45 46	34 35 36 37 38 39 40 41 42 43 44 45 46	34 35 36 37 38 39 40 41 42 43 44 45 46	34 35 36 37 38 39 40 41 42 43 44 45 46	34 35 36 37 38 39 40 41 42 43 44 45 46
<b>F24 Template</b>	47 48 49 50 51 52 53 54 55 56 57 58 59 60 61 62	47 48 49 50 51 52 53 54 55 56 57 58 59 60 61 62	47 48 49 50 51 52 53 54 55 56 57 58 59 60 61 62	47 48 49 50 51 52 53 54 55 56 57 58 59 60 61 62	47 48 49 50 51 52 53 54 55 56 57 58 59 60 61 62	47 48 49 50 51 52 53 54 55 56 57 58 59 60 61 62	47 48 49 50 51 52 53 54 55 56 57 58 59 60 61 62	47 48 49 50 51 52 53 54 55 56 57 58 59 60 61 62	47 48 49 50 51 52 53 54 55 56 57 58 59 60 61 62	47 48 49 50 51 52 53 54 55 56 57 58 59 60 61 62	47 48 49 50 51 52 53 54 55 56 57 58 59 60 61 62	47 48 49 50 51 52 53 54 55 56 57 58 59 60 61 62

**Note:**  
**Symmetrical joints: use red column.**  
**Asymmetrical joints: use grey column**

Numbers in white column are number of board sockets and pins

## CHAPTER 6

## Box Joint Procedures

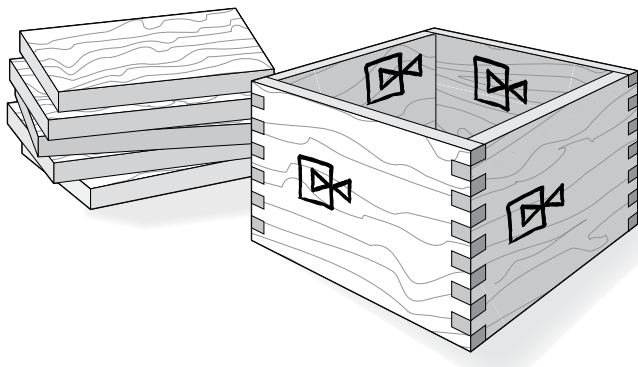

**6-1** Always use scrap boards to test for fit. Scrap width and thickness is not critical. Let's rout some simple box joints. These general instructions apply to any of the comb sizes. Rout single corners to test joint fit. *Note: This chapter combines instruction for joint procedures and joint fit. Follow through step by step the first time, but there is also a "quick fit test" method; see 9-2.*

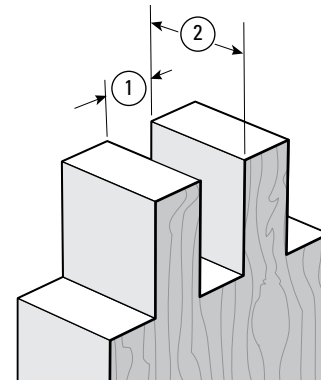
**6-2 Bit and e-Bush Selection**

There are no hard and fast rules for sizing of pins and sockets for box joints; but typically the sockets ① are one half to one quarter of the board thickness ②. Generally, the smaller the bit, the greater the strength because of the greater gluing area.

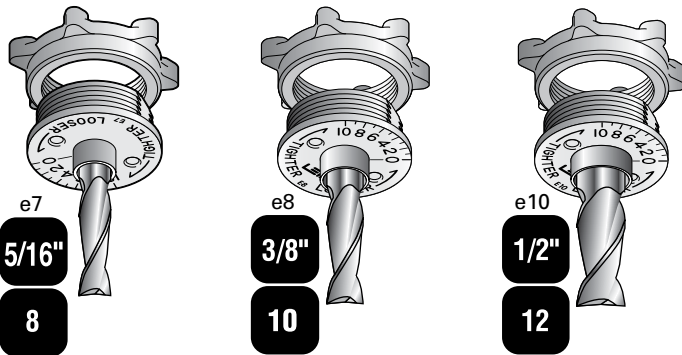

**6-3** Select the correct e-Bush and bit combination for the comb size to be used. The bit size is the same as the designated comb size.

*For smaller and larger size box joints see chapter 8.*

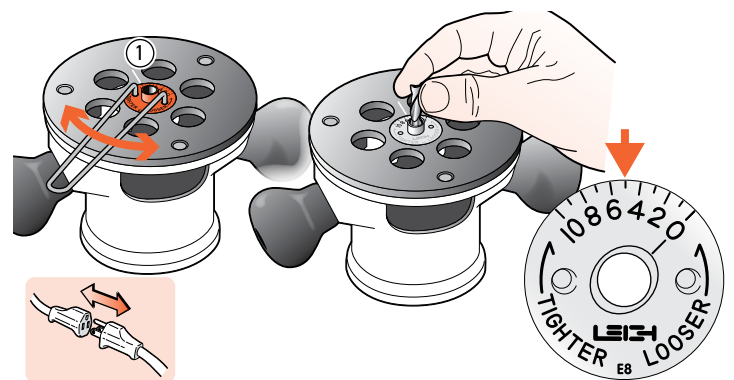

**6-4** Always start test routing with the e-Bush ① set on "5". Fit the selected bit (that matches the e-Bush and comb size) to the router and tighten securely.

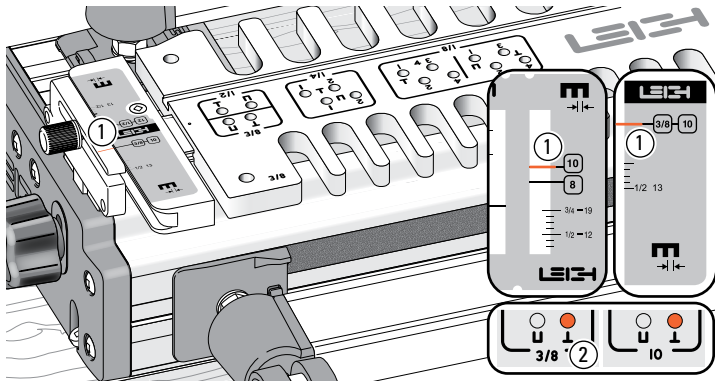

**6-5** Set the scale on the comb size to be used (example here;  $\frac{3}{8}$ " [10mm] comb ①). Position the template with the template pin in position ②. Remember, position the template pin at the opposite end of the template out of the way of the router.

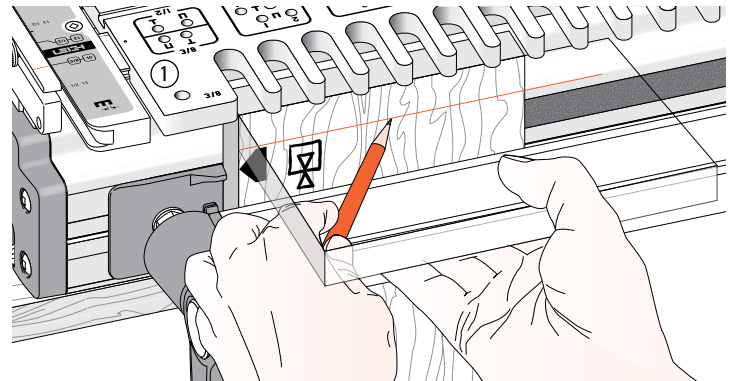

**6-6** Clamp the workpiece against the left-hand side stop; end edge flush under the template. Either face can be out . Mark and adjust depth of cut to suit the board's thickness. Use the board to be joined to mark the depth of cut. Templates have pin holes ① on the left end to allow routing wide boards at the right hand end or a different comb size.

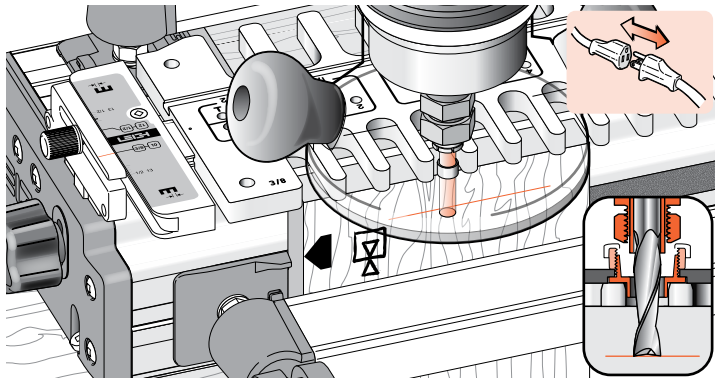

**6-7** Adjust the bit to cut at the centre of the pencil line. Make sure the collet will not rub on the guidebush.

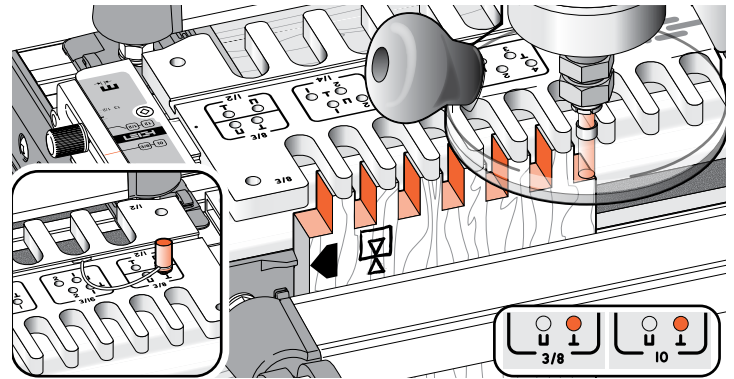

**6-8** Rout one end of a scrap board. Make sure to touch the guidebush on both sides of each template opening.

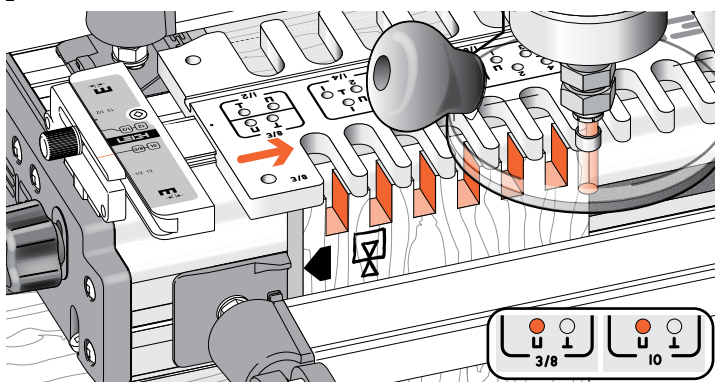

**6-9** Remove the template pin and move the template to position **U**, then refit the pin. Rout the mating board.

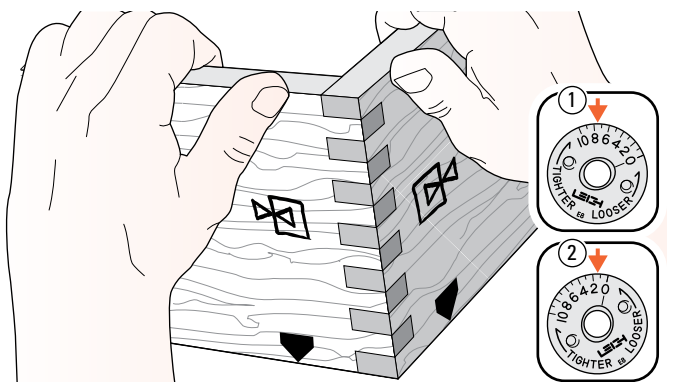

**6-10** Test the two boards for fit. Adjust the **e-Bush** by trial and error and rout more pairs of test boards to achieve the desired fit. Remember, turn the e-Bush "up" to a tighter joint ① and "down" for a looser joint ②.

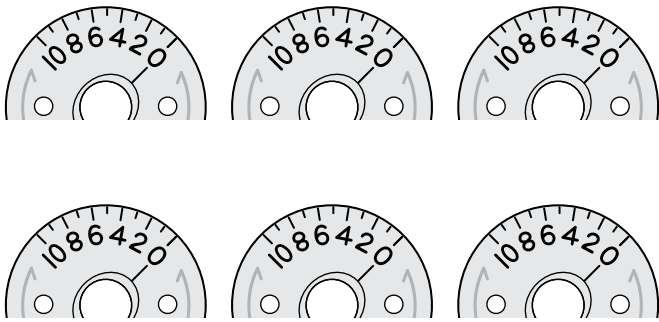

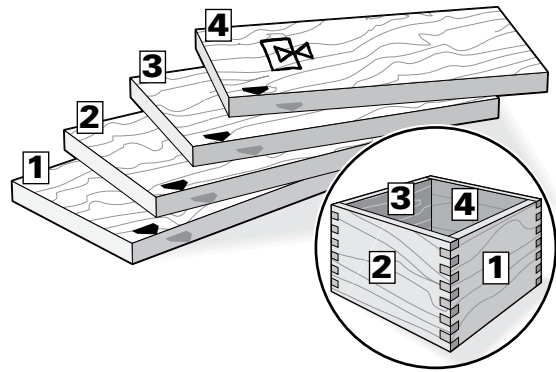

**6-11** When the fit is just right, mark the e-Bush setting here or on page 10 for future reference.

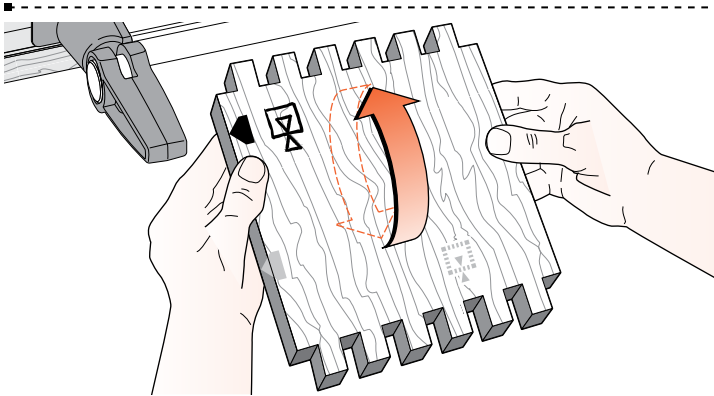

**6-12 Let's make a box.**

Prepare four boards and mark them **1, 2, 3,** and **4**. Then select the grain alignment and mark the common top (or bottom) edge. Don't worry about face side selection, this can be done after routing.



**6-13** All square box joint boards (for boxes or end-on-end joints) are clamped alternately face in and face out , always with the same side edge against the side stop.

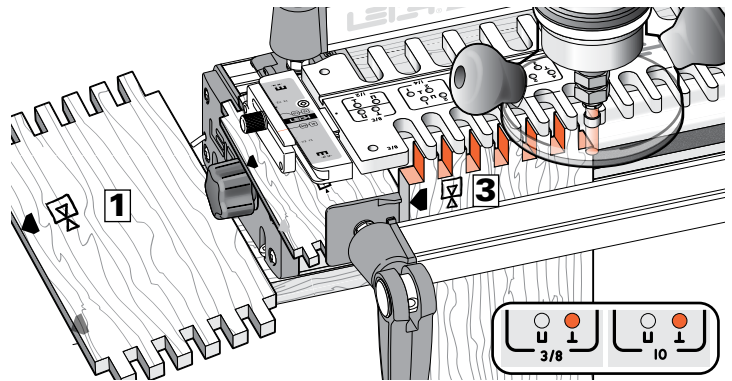

**6-14** Rout both ends of boards **1** and **3** in position **1**. Be sure to keep the same edges to the side stop.

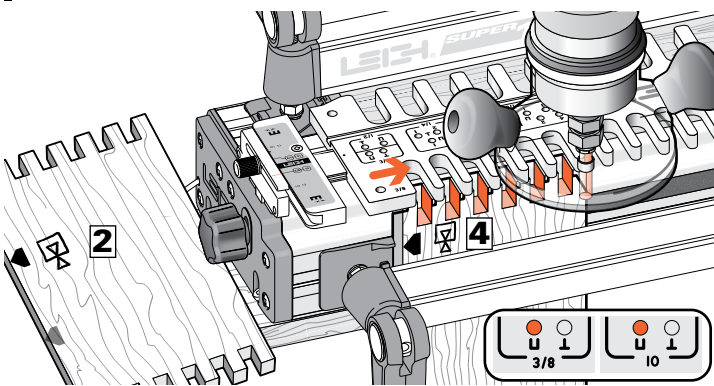

**6-15** Rout both ends of boards **2** and **4** in position **U**. Keep the same edges to the side stop.

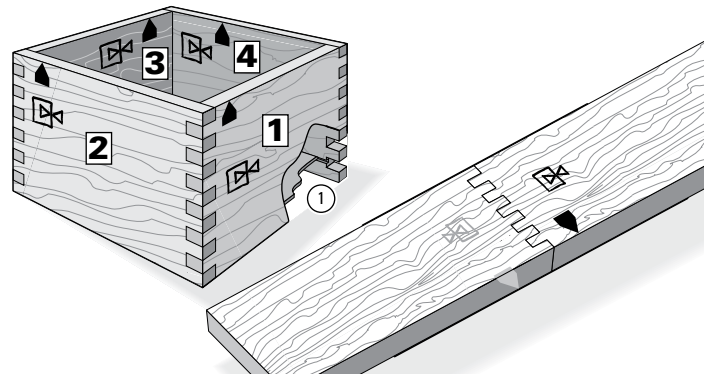

**6-16** Keeping the marked side stop edges of all boards toward the top (or bottom) of the box, select the preferred outside faces before marking and routing the grooves **1** for the box bottom. Remember, box joint corners need clamping from both directions, or use strap clamps and blocks. The same method will produce square end-on-end joints. ■



## CHAPTER 7

## Half-Blind Box Joint Procedures

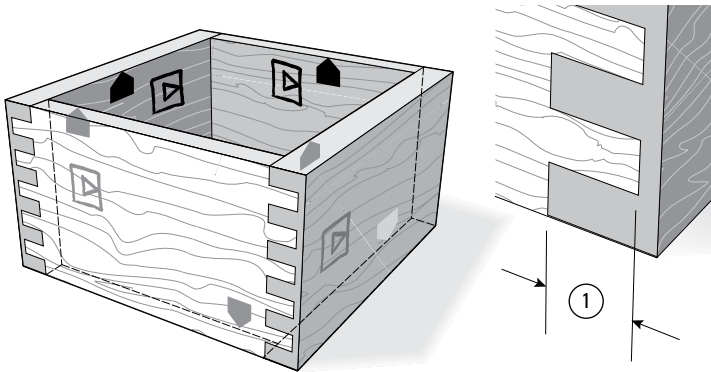

**7-1 Half-Blind Joints** Unlike normal box joints, the inside faces of half-blind box joint boards always face away from the jig body, and alternate edges are placed against the side stop. Set the depth of cut ① to about  $\frac{1}{8}$ " [3mm] less than the drawer-front thickness. Use only the "Symmetrical" board widths for half-blind joints.

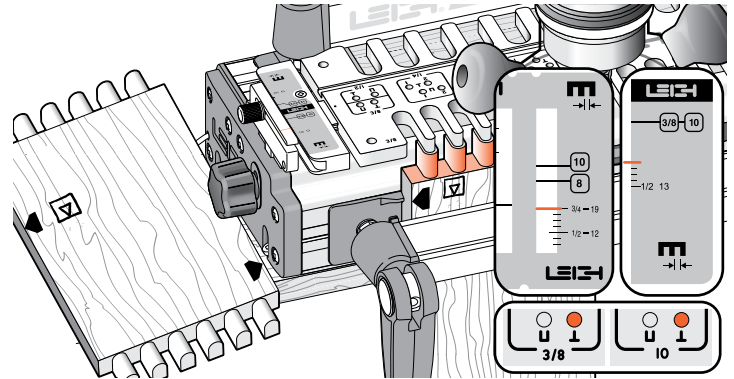

**7-2** Set the template pin on the **L** setting and the scales to the thickness of the box sides, e.g.  $\frac{3}{4}$ " [20mm] shown here. Rout the box side ends vertically in the front clamp.

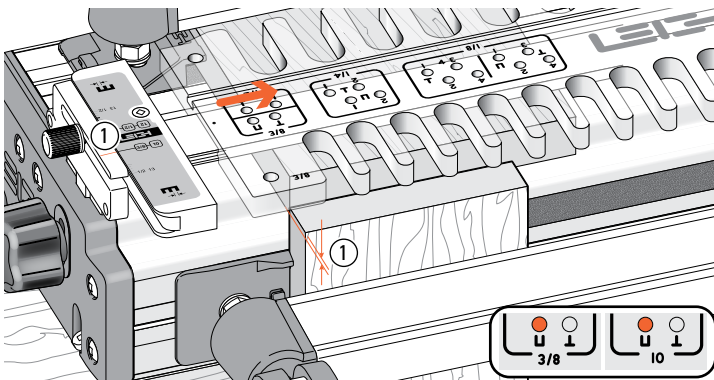

**7-3** Set the template pin on **U**. Clamp a scrap piece vertically in the jig front with its top end slightly above the jig body ①. Clamp a box front horizontally with the inside face **□** away from the jig body, and the front end edge against the scrap board.

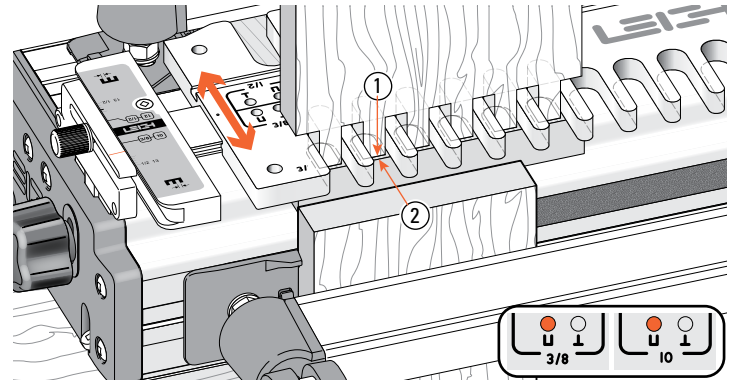

**7-4** Place one of the routed box sides vertically through the template with the rounded part of the fingers in the rounded guide crotches. Adjust the template so the front face of the side board ① is  $\frac{1}{16}$ " [1,5mm] in from the end edge of the box front ②. Lock the scales on the same setting at both ends.

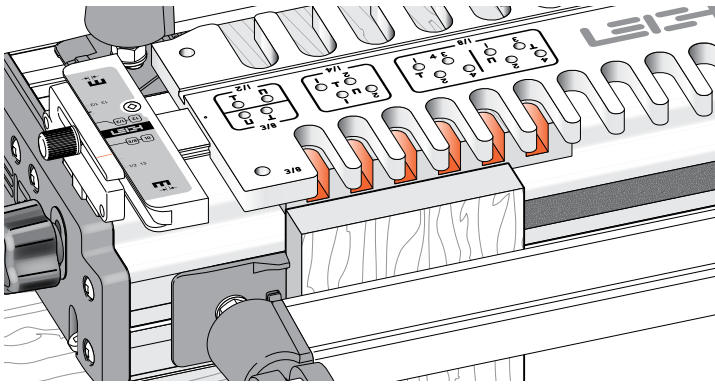

**7-5** Rout a test piece to test the scale setting for joint flushness and adjust the template in or out to produce the required flush fit.

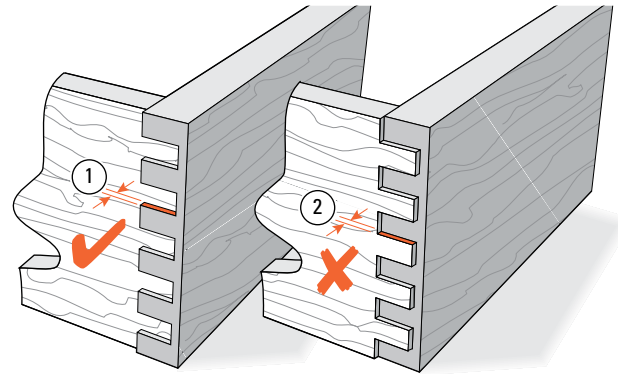

**7-6** The drawer front pins should project through the side sockets by no more than  $\frac{1}{64}$ " [0,25mm] for clean-up ①. If the sides project ②, adjust the template inward to suit.

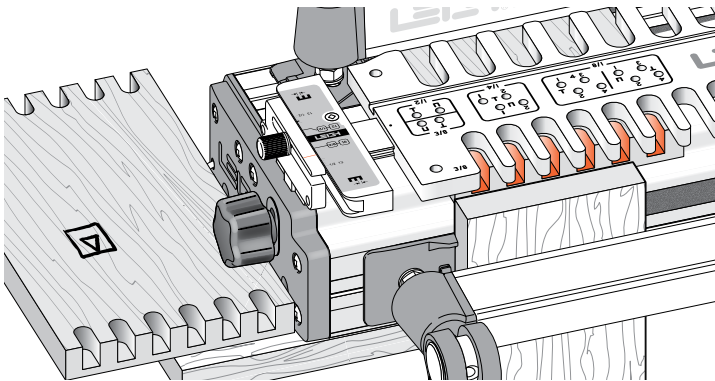

**7-7** When satisfied with the flushness fit, rout all the ends of the box fronts and backs in this mode.

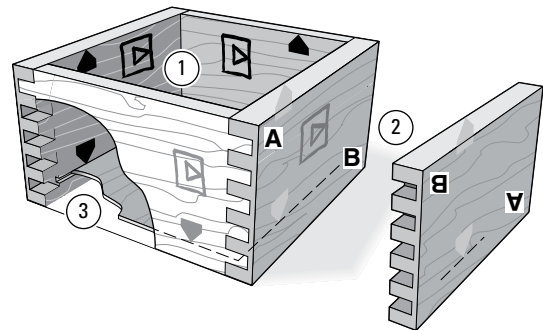

**7-8** Square half-blind box joint boards must be assembled with the inside faces inwards ① but unlike normal box joints, the sides edges may be up or down ②. So you can decide on the preferred board orientation before marking and routing the box bottom grooves ③. You will probably need to clamp in both directions when gluing-up.

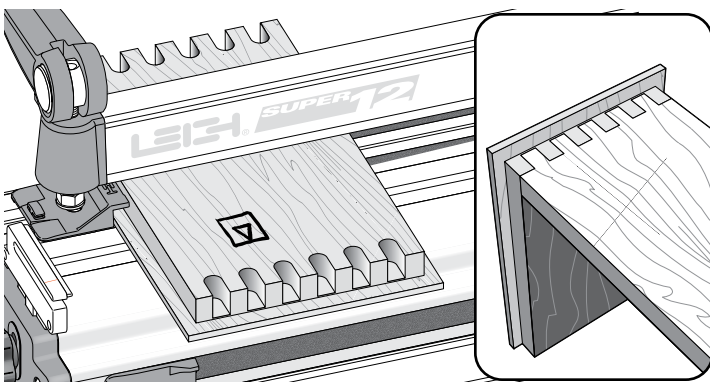

### 7-9 Rabbeted Half-Blind Box Joints

Rabbeted half-blind workpieces do not require blocking on D4R and SuperJigs if the rabbet is  $\frac{3}{8}$ " or less.

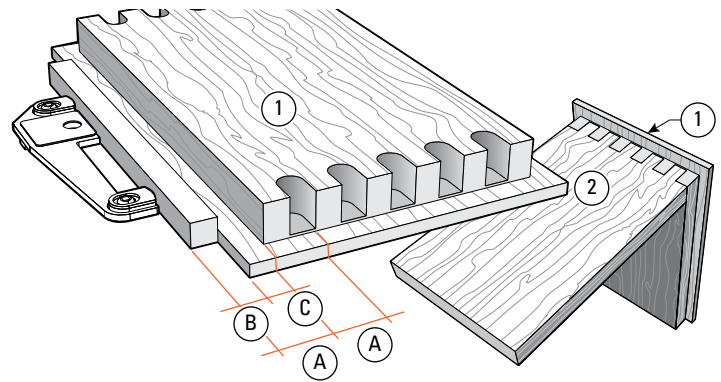

### 7-10 Rabbeted Joints on older D-Series Jigs

Rabbeted drawer fronts ① and the mating sides ② have to be blocked away from the side stops. Block drawer sides ② away from the side stops by one complete comb pitch (A). Block the drawer front ① away by (B) which is comb pitch (A) minus rabbet width (C). ■



CHAPTER 8

# Half, Quarter & Double Size Box Joints

This chapter covers procedures for routing 1/2 size and 1/4 size joints on the F3, F3M, F18, F18M, F24 and F24M Finger Joint Templates. Not all joint sizes are available on all templates. See the chart below for joint size information for each template. These instructions assume that you have mastered basic box joint routing, are thoroughly familiar with those procedures, and that you have read the Hints and Tips Chapter 9.

## LEIGH FINGER (BOX) JOINT SIZES

Inch Templates	Full Size (Inches)			Half Size (Inches)			Quarter Size (Inches)		Half-Blind (Inches)			Double Sizes (Inches)		
	<b>F3</b>	5/16	3/8	1/2	5/32	3/16	1/4	3/32	1/8	5/16	3/8	1/2	5/8	3/4
<b>F18</b>		3/8	1/2		3/16	1/4	3/32	1/8		3/8	1/2		3/4	1
<b>F24</b>		3/8	1/2		3/16	1/4	3/32	1/8		3/8	1/2		3/4	1
Metric Templates	Full Size (mm)			Half Size (mm)			Quarter Size (mm)		Half-Blind (mm)			Double Sizes (mm)		
	<b>F3M</b>	8	10	12	4	6	2	3	8	10	12	16	20	24
<b>F18M</b>		10	12		5	6		3		10	12		20	24
<b>F24M</b>		10	12		5	6		3		10	12		20	24

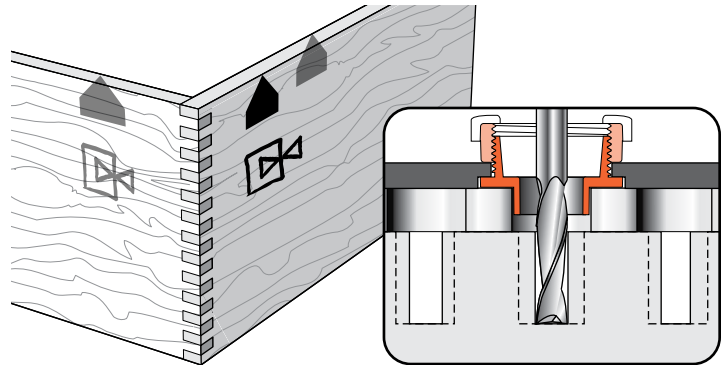
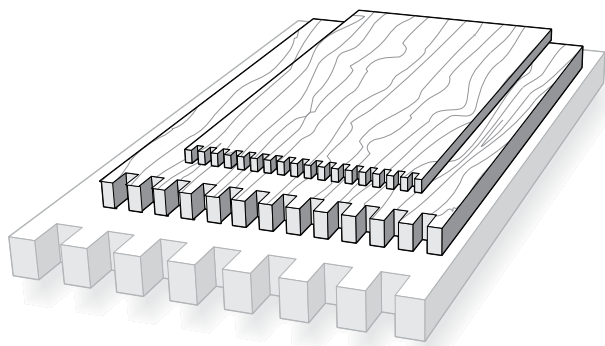

### 8-1 About Small Box Joints

The template pin positions for half and quarter size joints are clearly marked on the template. These allow routing of half-size, and even some quarter-size box joints using the same procedure.

To calculate board widths for small box joints, see 8-19 to 8-21.

### 8-2 Routing Half-Size Joints

Use the same size guidebush for the selected comb, but use a bit half the nominal size. An example of a half size joint layout is routing 3/16" [5mm] joints on the 3/8" [10mm] comb. In this example, use the e8-Bush with a 3/16" [5mm] bit.

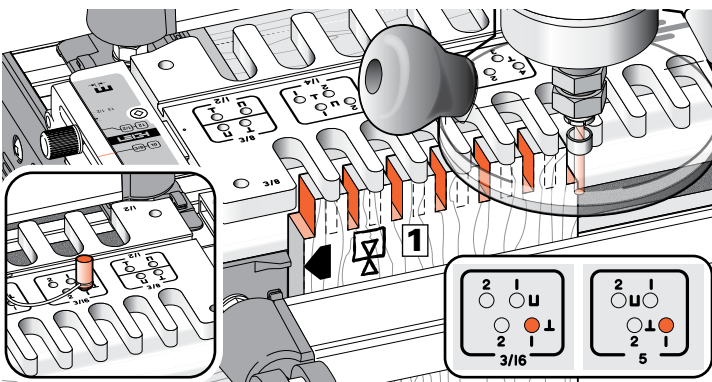

**8-3** Clamp board **1** in the jig against the side stop. Using the 3/16" [5mm] pin-hole panel (right-hand end of the template), place the template pin in the **1** No.1 hole. Rout the 3/16" [5mm] sockets and leave board **1** in the clamp.

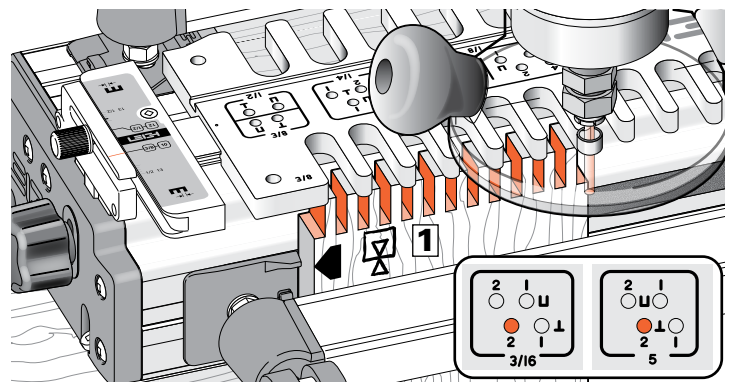

**8-4** Move the template right. Put the template pin in the **2** No.2 hole. Rout the remaining sockets and remove the board. Board **1** now has fingers and sockets half the nominal size. Repeat 8-3 and 8-4 on the other end of board **1**, and on both ends of board **3**, making sure at each step to keep the same side edge against the side stop.

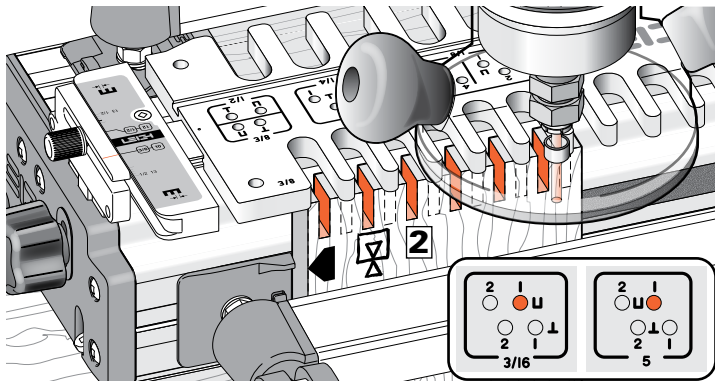

**8-5** Mount the mating board **2**. Put the template pin in the **U** No.1 hole. Rout the first set of sockets and leave the board in the clamp.

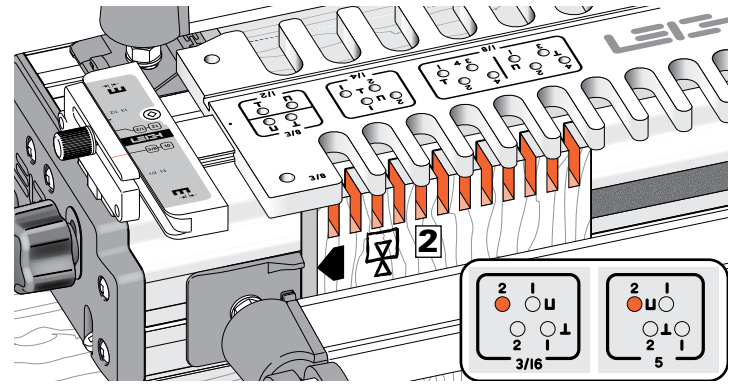

**8-6** Move the template and put the template pin in the **U** No.2 hole. Rout the remaining sockets and remove the board. Repeat instructions 5 and 6 on the other end of board **2**, and on both ends of board **4**, again making sure to keep the same board side edge against the side stop.

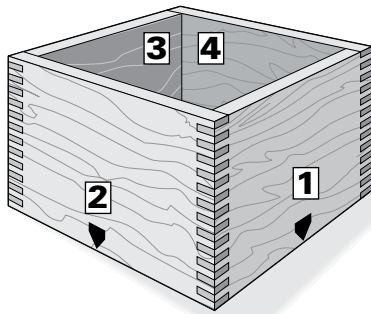

**8-7** Keeping the marked side stop edges of all boards toward the top (or bottom) of the box, select the preferred outside faces before marking and routing the grooves **1** for the box bottom. Remember, box joint corners need clamping from both directions, or use strap clamps and blocks. The same method will produce square end-on-end joints.

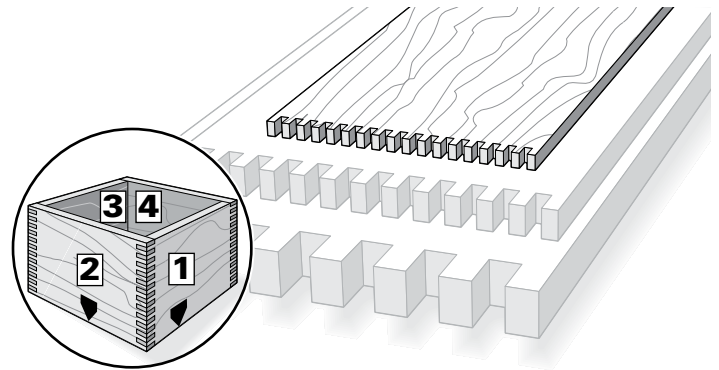

**8-8 Quarter Size Joints** Routing sequence is the same for all combs. Our example quarter size joint layout shows  $\frac{3}{32}$ " joints on the  $\frac{3}{8}$ " comb and e8-Bush. The metric templates only provide quarter size using the 12mm comb and e-10 Bush. This produces 3mm joints, so our example shows metric pin settings in the 3mm panel. Quarter size joints are not available on the F3  $\frac{5}{16}$ " comb

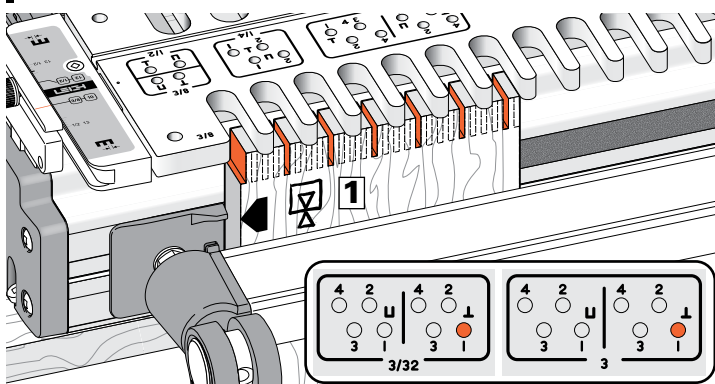

**8-9** Clamp board **1** in the jig against the left-hand side stop. Using the  $\frac{3}{32}$ " [3mm] pin-hole panel, place the template pin in the **L** No.1 hole and rout the quarter size  $\frac{3}{32}$ " [3mm] sockets. Leave the board in the clamp until after step 8-12.

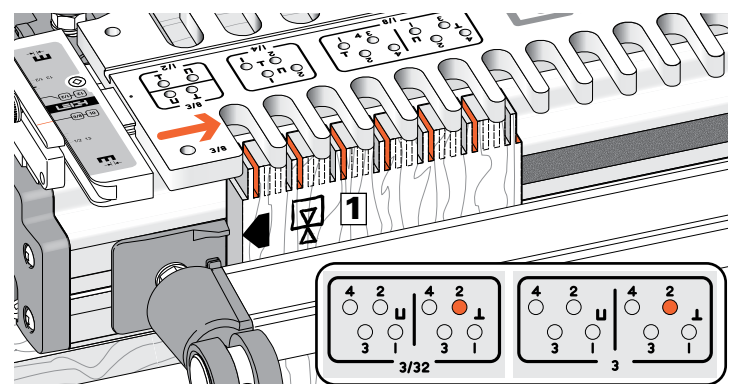

**8-10** Move the template and put the template pin in the **L** No.2 hole. Rout again.

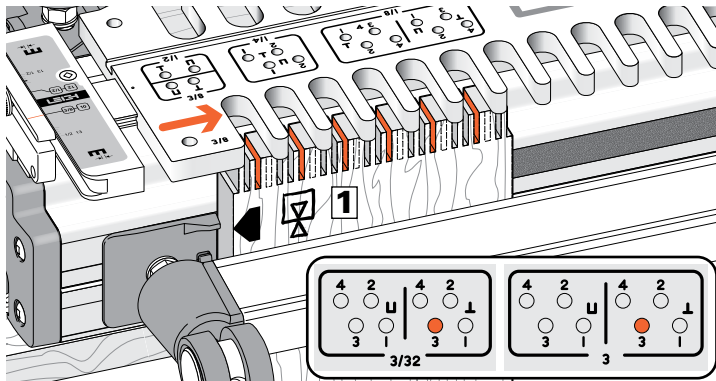

**8-11** Move the template, put the template pin in the **L** No.3 hole and rout again.

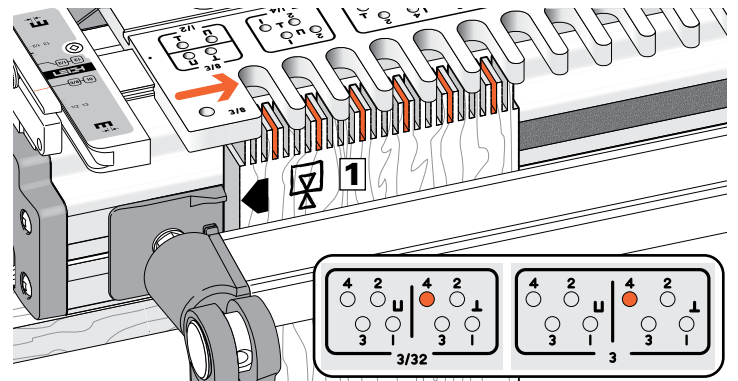

**8-12** Finally, move the template and put the template pin in the **L** No.4 hole. Rout the last sockets and remove the board.

Repeat instructions 9 through 12 on the other end of board **1**, and on both ends of board **3**, making sure at each step to keep the same side edge against the side stop.

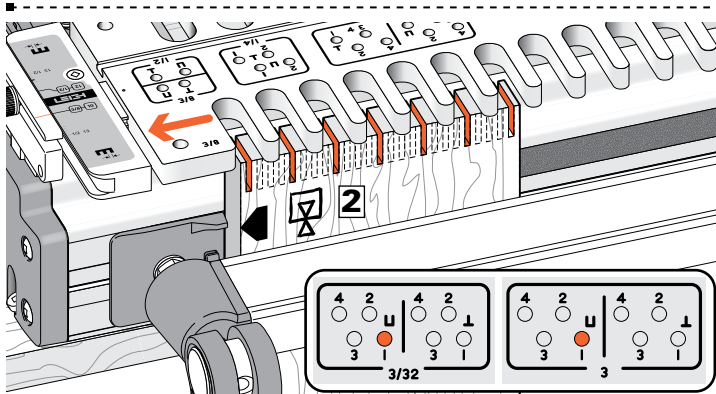

**8-13** Mount the mating board **2**. Put the template pin in the **U** No.1 hole and rout the first set of sockets. Leave the board in the clamp until after step 8-16.

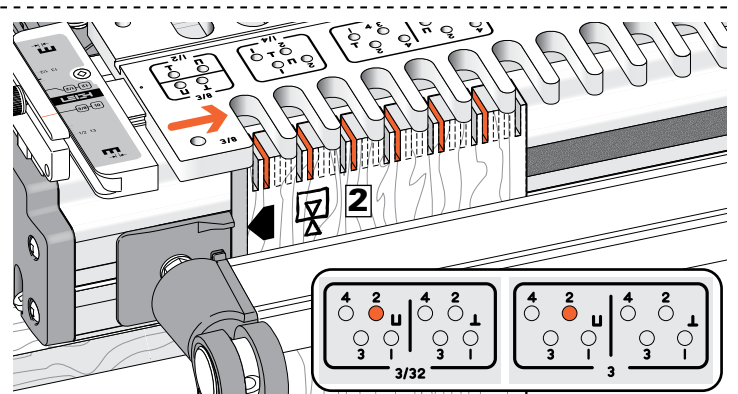

**8-14** Move the template and put the pin in the **U** No.2 hole. Rout the second set of sockets.

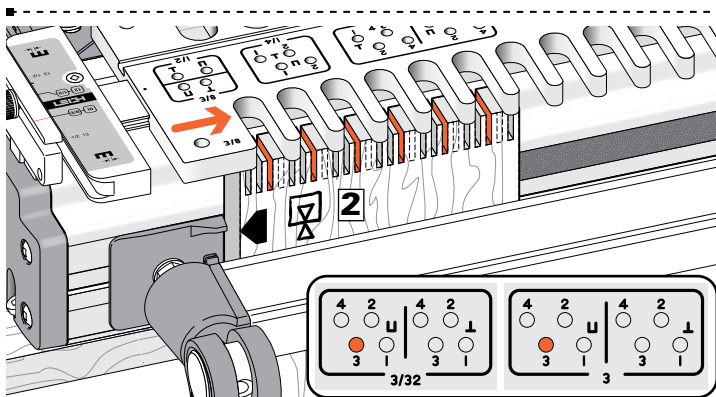

**8-15** Rout again in pin position **U** No.3.

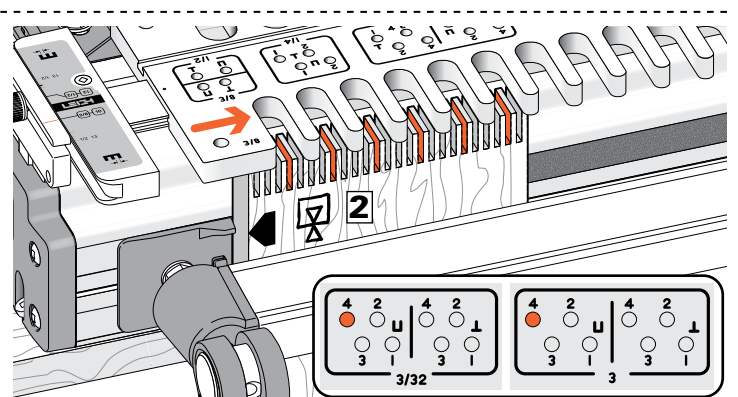

**8-16** Then rout in pin position **U** No.4.

Repeat instructions 13 through 16 on the other end of board **2**, and on both ends of board **4** making sure at each step to keep the same side edge against the side stop.

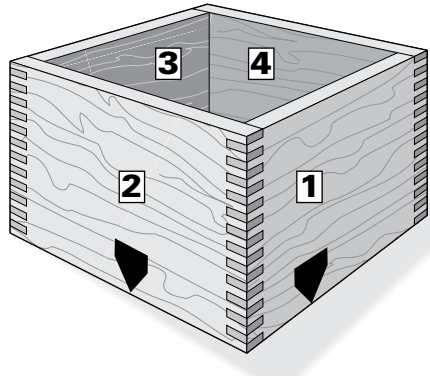

**8-17** During assembly of the box, always keep the side stop edges of the boards either to the top or bottom of the box.

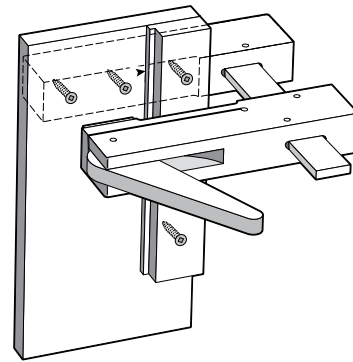

**8-18 A Fixture for Routing Multiple Pieces**

For very thin or short boards, make up an auxiliary clamp with its own *stepped* side stop by adapting a stock clamp. You can download instructions on how to make and use this fixture from: [www.leighjigs.com/support](http://www.leighjigs.com/support).

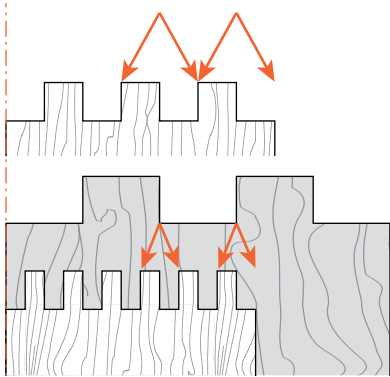

**8-19 Board Widths for Small Box Joints**

Small joint board widths are calculated from the board width charts, see page 12. e.g. for  $\frac{3}{16}$ " [5mm] joints use the  $\frac{3}{8}$ " [10mm] comb chart.

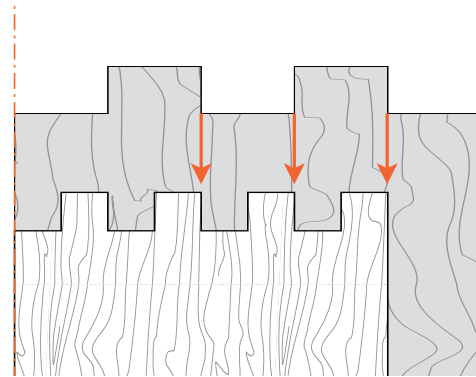

**8-20 Asymmetrical Joints, Half Size**  
Width as per chart.

**All Symmetrical Joints**

Use chart width plus or minus the diameter of the small cutter used.

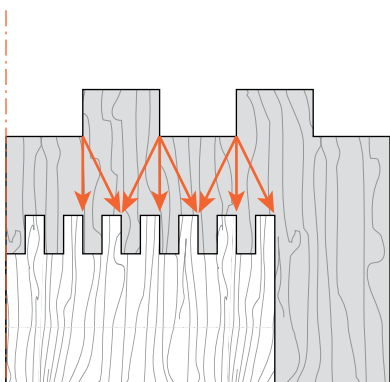

**8-21 Asymmetrical Joints, Quarter Size**

Chart width plus or minus 2 diameters of the small cutter used.

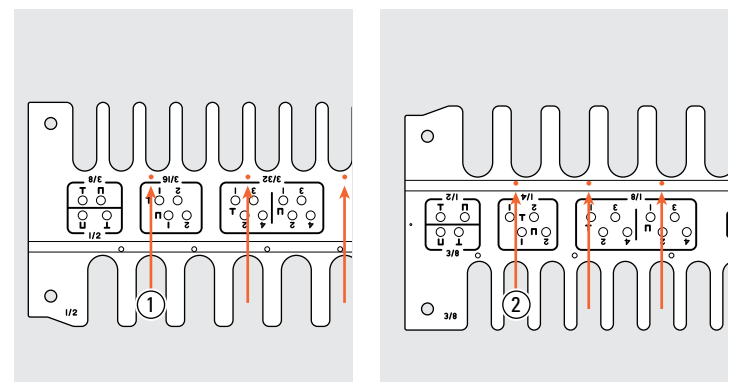

**8-22 Double Size Box Joints e.g.  $\frac{5}{8}$ ",  $\frac{3}{4}$ " & 1" [16, 20 & 24mm]**

This procedure requires routing into every second comb opening. To aid in "steering" the router we have machined "dots" opposite the  $\frac{1}{2}$ " [12mm] comb ① in the template surface, and opposite the  $\frac{3}{8}$ " [10mm] and  $\frac{5}{16}$ " [8mm] comb in the slot ②.

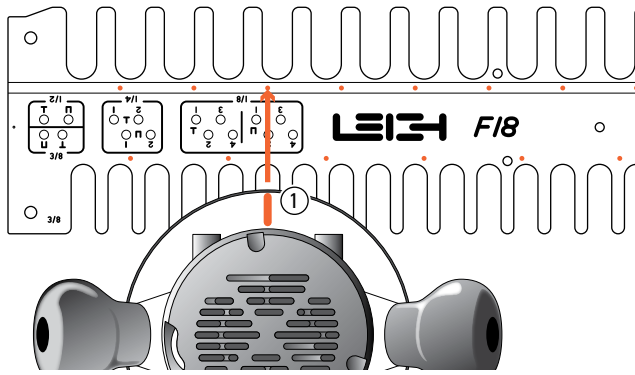

**8-23** Mark the top of the router base at the 12 o'clock position ①. This will simplify steering the router relative to the “dots”.

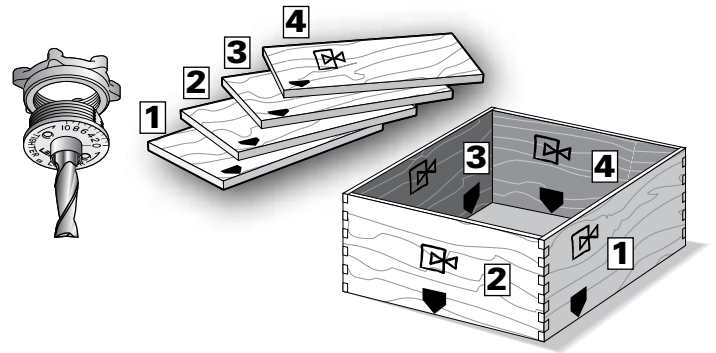

**8-24** Select the bit and e-Bush size, and referring to the Board Width chart, see page 12, prepare four boards. Number them **1** to **4** around the box, with the common edges marked. This example shows  $\frac{3}{4}$ " [20mm] joints on the  $\frac{3}{8}$ " [10mm] comb.

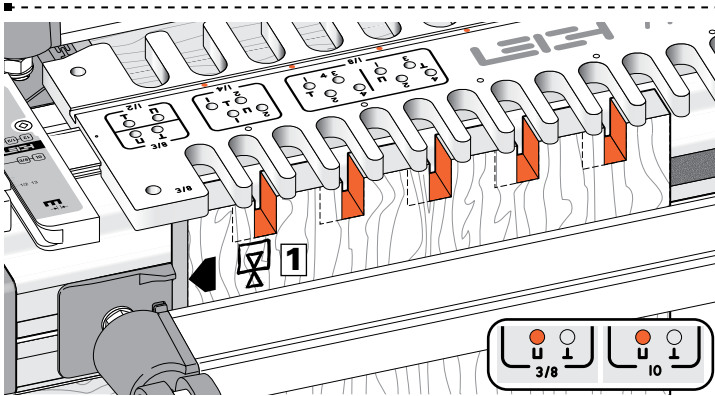

**8-25** Clamp Board **1** against the left side stop. Position the template in the **U** pin position. Rout into every second opening by steering the mark you made on the router toward the “dots” in the extruded slot ①. Leave the board clamped in position.

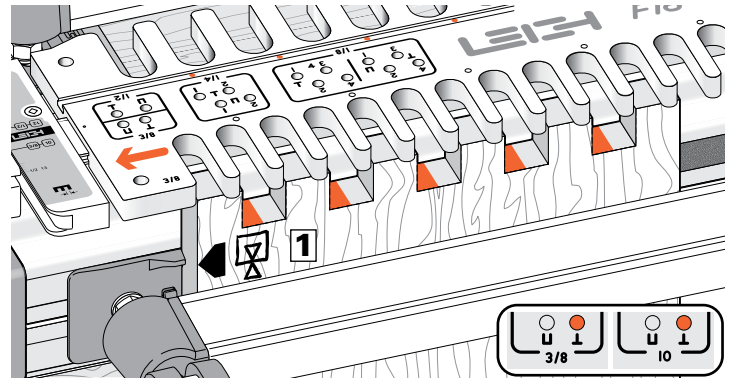

**8-26** Move the template to the **L** pin position and again rout into every second opening i.e. steering the base arrow toward the “dots”.

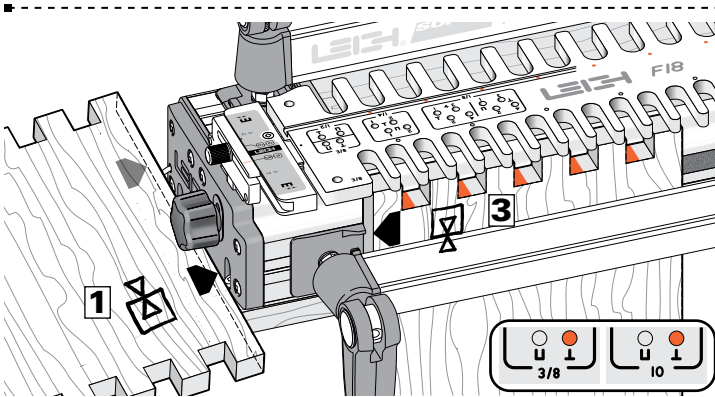

**8-27** Turn board **1** end for end (same side edge to the side stop and opposite face against the jig each time). Repeat steps 25 and 26 on this end of board **1** and on both ends of board **3**.

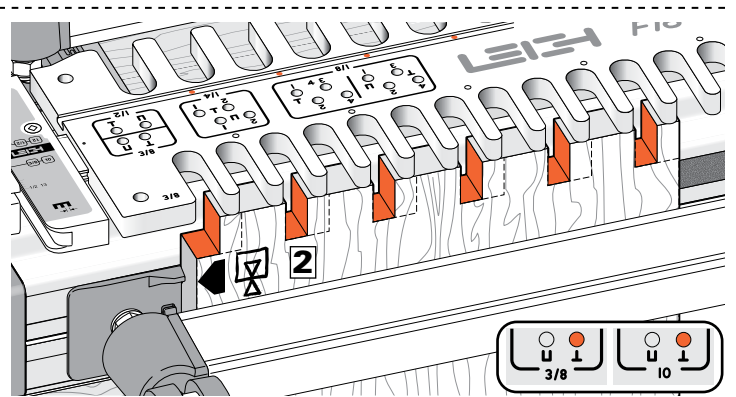

**8-28** Clamp Board **2**. Leave the template in the **L** pin position but this time rout into the first comb opening and every odd numbered opening. Steer the base arrow between the “dots”. Leave the board clamped in position.

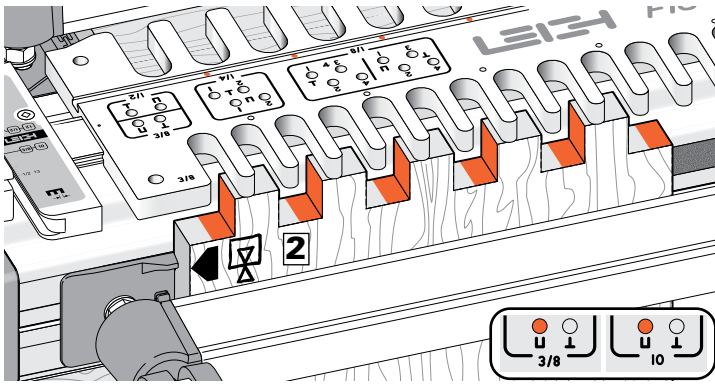

**8-29** Move the template to the **u** pin position and again rout into every odd opening, i.e. steering the base arrow between the “dots”.

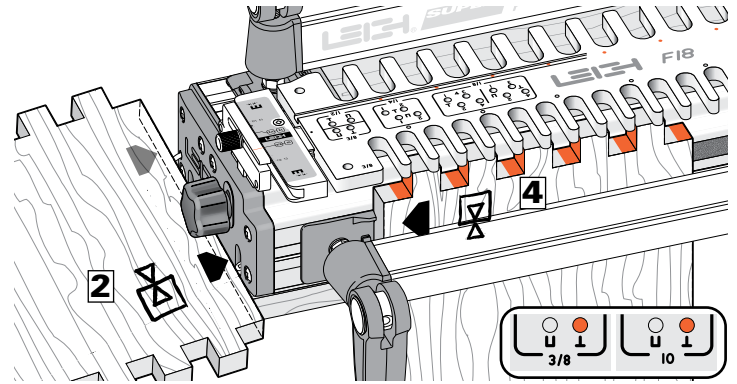

**8-30** Turn board **2** end for end (same side edge to the side stop and opposite face against the jig each time). Repeat steps 28 and 29 on this end of board **2** and on both ends of board **4**.

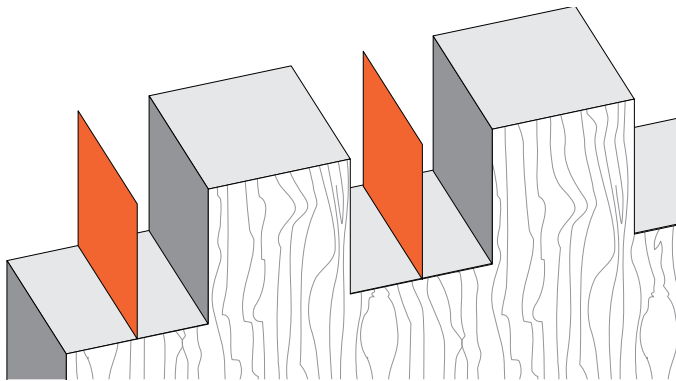

**8-31** Theoretically, there will be nothing in the sockets, literally a zero thickness wall, where the bit has passed by twice. However, routing tolerances can leave a very thin “wall” uncleared by routing. This can be quickly removed with a chisel or sandpaper.

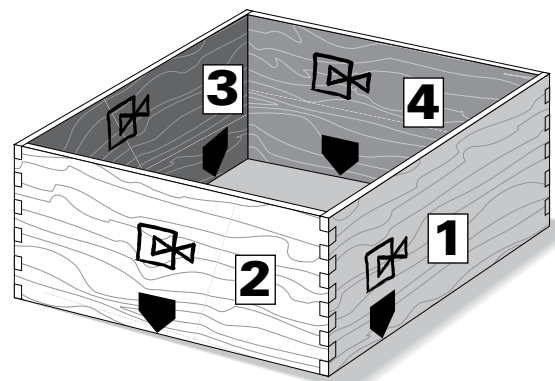

**8-32** Assemble the box with all four “side stop edges” either at the top, or at the bottom.

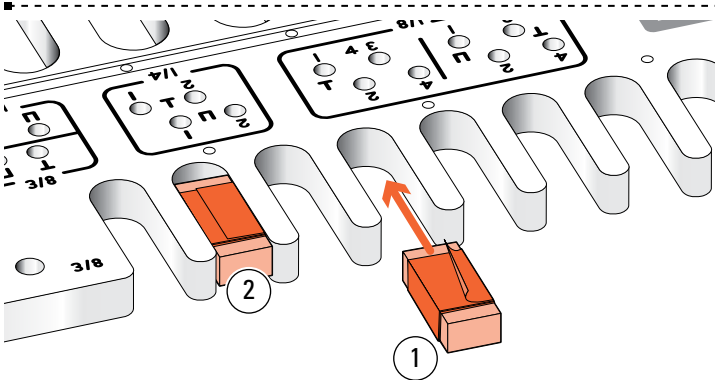

**8-33** Hint: If you are not very confident with the router, here is a foolproof way to rout the correct sockets. Cut some  $\frac{1}{4}$ " [6mm] thick wood strips, slightly narrower than the comb openings ①. Wrap with sufficient masking tape to create a snug friction-fit in the template ②. Fit them in openings you don't want to rout. ■

## CHAPTER 9

## Hints and Tips

Here are some special techniques and ideas to help you get the most out of your Leigh F Template.

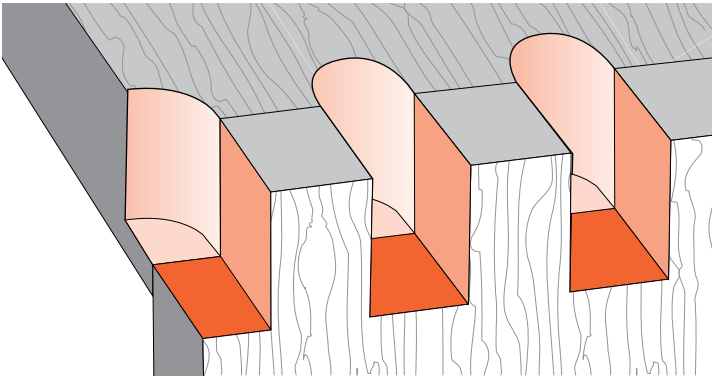

**9-1** To help prevent tear-out on the sides and bottom of the exit cut, back up the cut with a horizontal board end-grain pushed against the back of the workpiece and held in the rear clamp.

This same scrap piece can remain in place for successive cuts.

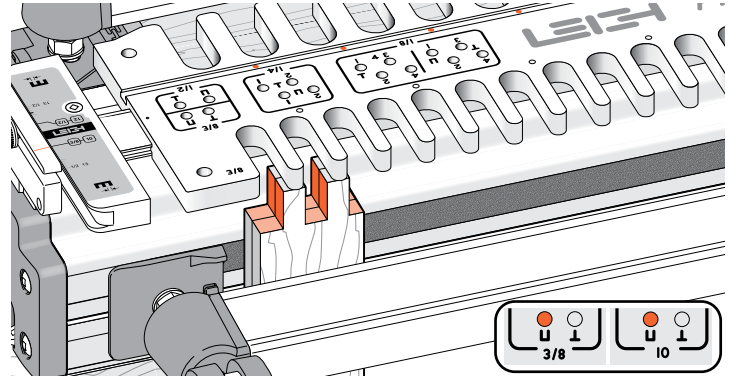

**9-2 Quick Fit Test** Rather than routing test pieces separately, here is a quick way to get 99% of the way there. Simply rout two thinner boards of scrap stock simultaneously. Any single pin position will do, unless you intend to rout small box joints, in which case, use the matching pin positions described in chapter 8. If you prefer, use one piece and saw in half after routing.

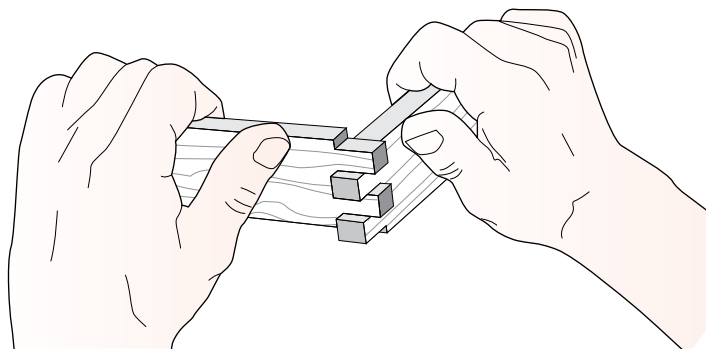

**9-3** Test for fit. Don't worry about board alignment, it's only the fit you're testing. Adjust the **e-Bush** by trial and error and rout more pairs of scrap board ends as required.

Once you have a good fit, rout a complete pair of separate test pieces in the **same species wood as the actual workpieces**, to test for final fit.

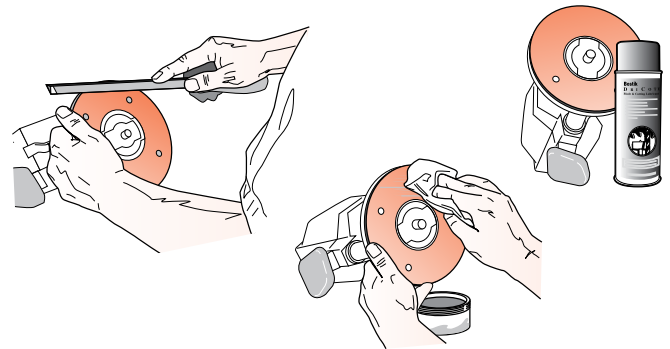

**9-4** Some router bases have sharp edges on the outside and inside corners. A slight chamfer of the edges with a fine file or sandpaper block will ease router movement on the jig. An occasional light spray of TopCote® or application of soft wax to the router base makes for smooth, easy router movement on the jig. ■





## Appendix I

# Attaching the Leigh e-Bush to the Router

## e-Bush and Guide Adaptors

The Leigh e-Bush fits directly to most popular router models such as Porter Cable, Black & Decker, and Dewalt. Many other makes, e.g. Bosch, Fein, Festool, Milwaukee etc., either offer or come complete with base adaptors that accept the e-Bush. In addition Leigh offers the nine adaptors below to allow the use of over one hundred other router models new and old.

See list of routers on the next page.

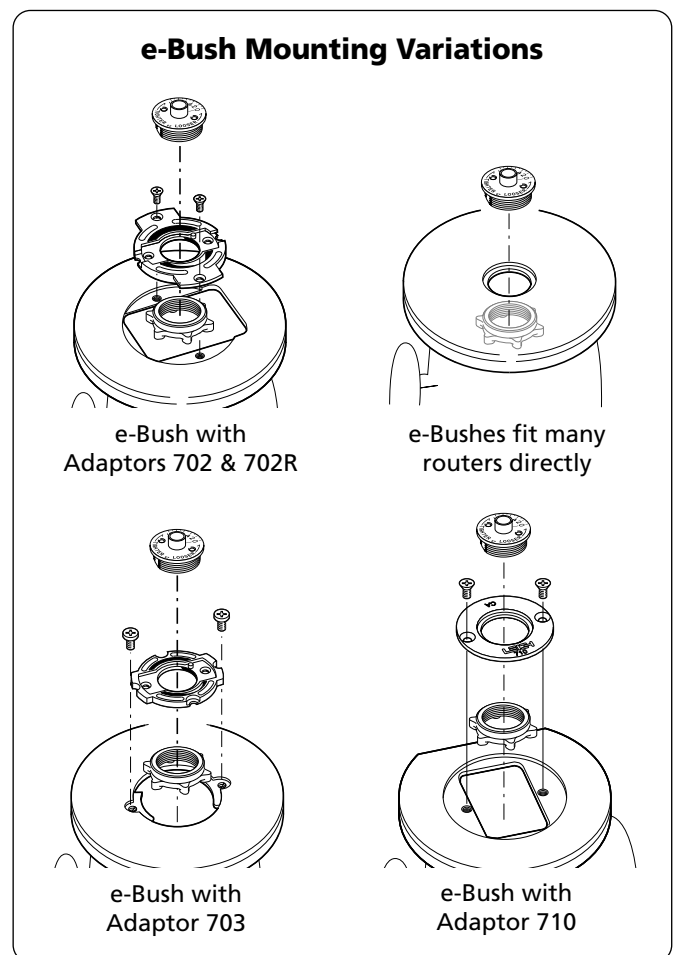
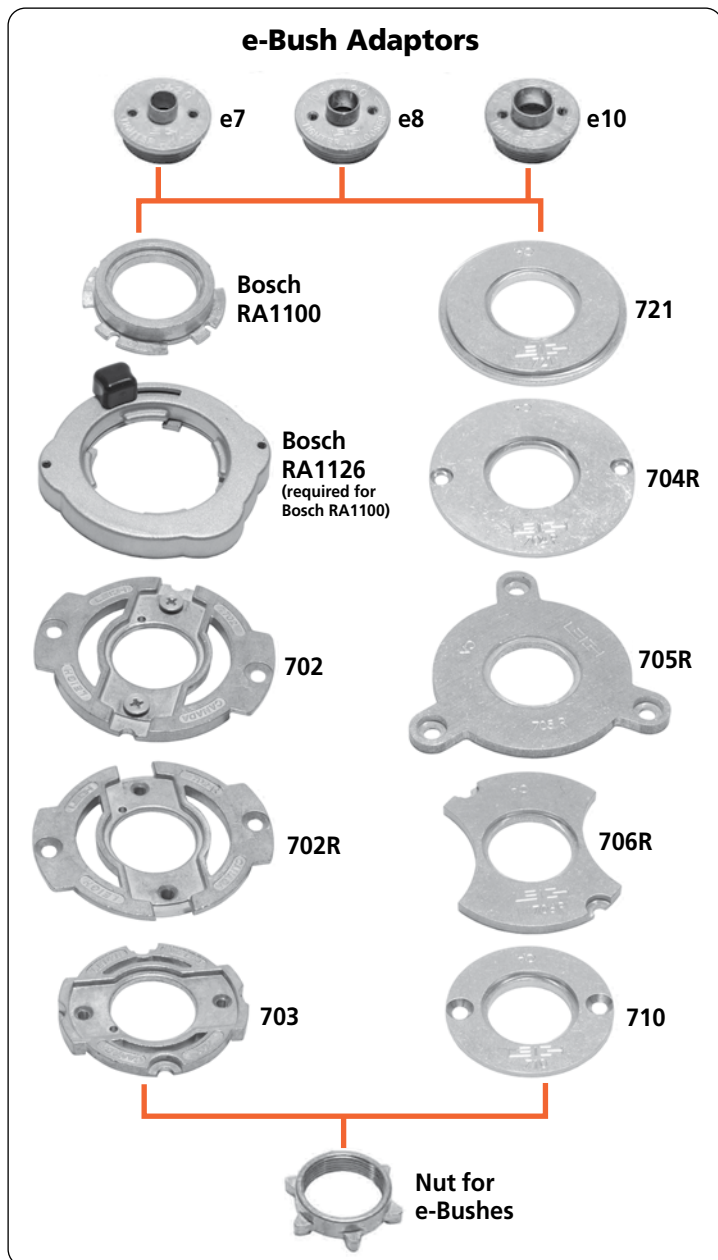

**eBush Adaptor Selection** Leigh dovetail jigs require a router fitted with a guide bushing. An adaptor may be required to fit the bushing to the router. *See [www.leighjigs.com](http://www.leighjigs.com) for the complete list of routers.*

**DIRECTIONS**

- A.** Locate name of router maker in Column 1.
  - B.** Locate router model in Column 2. If your router is not listed visit [leighjigs.com](http://leighjigs.com) for a complete, up-to-date list of routers.
  - C.** Locate adaptor required for your router in Column 3.
    - Order Leigh adaptors (part no's in red) in Column 3 from Leigh.
    - Order Bosch adaptors RA1100 and RA1126 in Column 3 from Leigh or your Bosch dealer.
    - Order all other adaptors in Column 3 from the router manufacturer's dealer.
- Note:** Adaptor mounting screws are included with router.

- **MAFELL** – Rework adaptor slightly.
- D.** Guide bushings in Columns 4, 5 and 6 fit all adaptors listed. Note the following:
  - ◆ A 7/16" e7 guide bushing is used only on the F3/M Template.
  - A 1/2" e8 guide bushing is used on F3, F18 and F24 Finger Joint Templates.
  - ▲ A 5/8" e10 guide bushing is used on F3, F18 and F24 Finger Joint Templates. Use only with 1/2" shank router bits on D4R Pro, D4R, D4, D3 and D1258(R) jigs, and 18" and 24" Super Jigs.

1 ROUTER MAKER	2 ROUTER MODEL	3 ROUTER ADAPTOR	4 7/16" OD BUSHING ◆	5 1/2" OD BUSHING ▲	6 5/8" OD BUSHING ▲
AEG	OFE 710 in plunge base	Not Required	e7	e8	e10
	OFSE 2000	703	e7	e8	e10
	RT1350E	706R	e7	e8	e10
BLACK & DECKER	All Professional, HD1250, RP400K, 7614	Not Required	e7	e8	e10
	6200	720673-00	e7	e8	e10
	SR100, 7AEE, KW780 series, KW800, KW850	710	e7	e8	e10
	90085, 90088, 90098, 90140, 90150, 90300, 90303, 90305, 91264	Aftermarket base plate required	e7	e8	e10
	1600, 1601, 1602, 1603, 1604, 1606, B1350	RA1110	e7	e8	e10
	North American ROUTERS PRODUCED AFTER mid-2010: 1613EVS, 1613AEVS, 1617, 1617EVS, 1618, 1618EVS, 1619EVS, MR23EVS, MRC23EVS, MRF23EVS, MRP23EVS	RA1126 quick change adaptor and RA1100 bushing adaptor req'd	e7	e8	e10
BOSCH	North American ROUTERS PRODUCED BEFORE mid-2010 and others available worldwide that include the RA1126 adaptor: 1613(EVS) (AEVS), 1614(EVS), 1617EVS, 1618EVS, 1619EVS, B1450, GOF900(CE) (ACE), GOF1200, GOF1250(CE)(LCE), GOF1300(CE)(ACE), GOF1600CE, GOF2000CE, GMF1400, GMF1600CE, POF800ACE, POF1100AE, POF1200AE, POF1400ACE	RA1100	e7	e8	e10
	1611, 1611EVS, 1615, 1615EVS, B1550, GOF1600, GOF1700ACE	702	e7	e8	e10
	All non-plunge models	Aftermarket base plate required	e7	e8	e10
CRAFTSMAN (SEARS)	135275070 Plunge	See Skill 1823 or 1835			
	Other plunge models	702	e7	e8	e10
	MD11 Plunge & Fixed Base, MD9.5 Fixed Base	Not Required	e7	e8	e10
DEWALT	DW610, DW616, DW618	Not Required	e7	e8	e10
	DW613, DW615(JK)	710	e7	e8	e10
	DW614, DW615, DW621, DW624, DW625, DW626	N. America Only, Supplied w/router	e7	e8	e10
	DW621K, DW622 and DW626 outside N. America	706R	e7	e8	e10
	DW625 Type 1,2,3,5 outside N. America	702	e7	e8	e10
	DW624 & DW625 Type 4 outside N.America, DW625EK	702R	e7	e8	e10
ELU	OF15, OF15E, OF97, OF97E	706R	e7	e8	e10
	MOF68, MOF69, MOF96, MOF96E	710	e7	e8	e10
	MOF131, MOF177 Type 1,2, & 3	702	e7	e8	e10
	MOF177 Type 4, MOF177EK	702R	e7	e8	e10
	2720, 2721, 3328	Not Required	e7	e8	e10
	3303, 3304	E09600 or 761 270-00	e7	e8	e10
FEIN	3337, 3338, 3339	702	e7	e8	e10
	RT1800	Supplied w/router	e7	e8	e10
	OF1E, OF2E, OF650, OF900E, OF1000, OF1010E	704R	e7	e8	e10
FESTOOL	OF2000, OF2000E	705R	e7	e8	e10
	OF1400 and OF2200 North America Only	Supplied w/router	e7	e8	e10
	OF1400 Outside North America	493566	e7	e8	e10
	OF2200 Outside North America	494627 O-Ring may be required to keep bushing centered	e7	e8	e10
FREUD	FT1700(2), FT2000, FT2200, FT3000	721	e7	e8	e10
HITACHI	TR8, TR12, FM8, M8, M12 Series	325211 OR 703	e7	e8	e10
	M12VC, KM12SC, KM12VC	Not Required	e7	e8	e10
	M12SA2, M12V2	325224	e7	e8	e10
MAFELL	L065E	702 ■	e7	e8	e10
MAKITA	M363, MRP090, RP1800(F), RP1801(F), RP2300(FC), RP2301(FC), 3612C Europe Qk Fit Base	721	e7	e8	e10
	3600, 3606, 3608, 3612, 3612B, 3612BR, 3612C N. America, 3620, 3621, RP0900, RP900K	703	e7	e8	e10
	3601B	321 493-1	e7	e8	e10
	RP0910, RP1110C	706R	e7	e8	e10
	RF1100, RF1101, RD1100, RD1101, RP1101	Not Required	e7	e8	e10
MASTERCRAFT	Please contact Leigh for assistance				
METABO	OF1612, OFE1812 (for all others, please contact Leigh for assistance)	704R	e7	e8	e10
MILWAUKEE	5615, 5616, 5619	49-54-1040 (replacement base)	e7	e8	e10
	5625	49-54-1026 (replacement base)	e7	e8	e10
	5670	Not Required	e7	e8	e10
PERLES	OF808 Series, OFE6990	710	e7	e8	e10
PORTER CABLE (ROCKWELL)	All	Not Required or Supplied w/router	e7	e8	e10
RIDGID	R2930 (for all others, please contact Leigh for assistance)	704R	e7	e8	e10
RYOBI	R30, R50, R150, R151, RE155, R500, R501, R502	703	e7	e8	e10
	R600, R601, RE600, RE601	702	e7	e8	e10
	R160, R161, R162, R163K, R165, R170, R175, RE175, R180, R180PL, R181, R185, ERT1150	706R	e7	e8	e10
	1823 or 1835	91803	e7	e8	e10
SKIL	SK1810, 1815, 1820, 1825	RAS140	e7	e8	e10
	All others	Aftermarket base plate required	e7	e8	e10
	T3, T4, T5, T9, T10, T11 – UniBase required	710	e7	e8	e10
TRITON	TRC001	TGA006 or 704R	e7	e8	e10
	JOF001, MOF001, TRA001	Accessory Kit (includes adaptor) TGA001 or TGA150	e7	e8	e10
WEGOMA	OF850 Series	710	e7	e8	e10

## Appendix II

## Bit and Joint Specification

## Bit Selection and Joint Specification

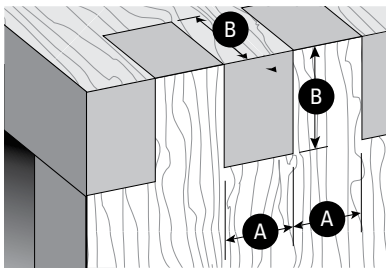
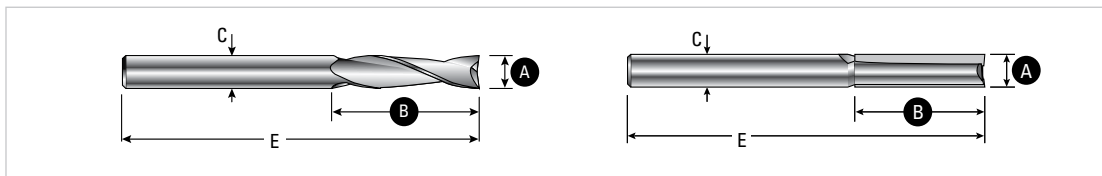

Virtually any straight router bit may be used for routing box joints or finger joints. There are two types which each have their own advantages and disadvantages. Generally, the high-speed steel (HSS) spiral upcut bits cut cleaner and have less tendency to cause tear-out. They also tend to pull the waste chips up to and around the guidebush, necessitating the occasional cleaning of the guide surfaces. Straight-flute carbide tipped bits spray the waste out horizontally, but they do not cut quite as cleanly.

“A” is the bit diameter and equals the nominal size of the finger or socket.

“B” is the cutting depth or board thickness, whichever is less.

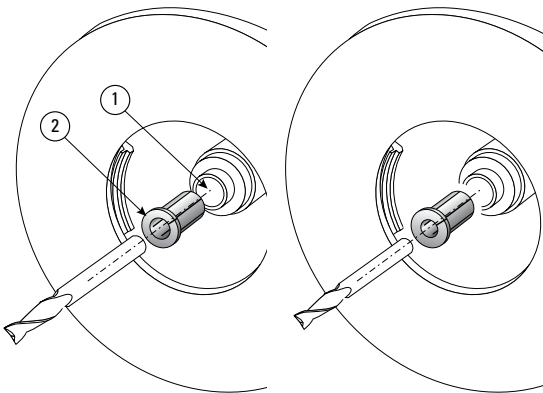

Check the shank size of each bit selected, then use the appropriate collet ① or collet reducer ②. 1/4" collet reducers come standard with most 1/2" collet routers, but **if 5/16", 8mm or 3/8" collets are not available, use one of the following:**

For all 3/8" shank bits use the Leigh No. 172-375, 1/2" to 3/8" collet reducer.

For all 5/16" and 8mm shank bits (*these are almost the same diameter*), use Leigh No. 172-8, 1/2" to 8mm collet reducer.

*See the next page for Bit Selection and Joint Specification charts.*

### Bit Selection and Joint Specification Charts

Note: In the following charts, the letters A, B, C, and E correspond to the drawings on the previous page.

#### F3 (Inches)

LEIGH BIT NO.			A	B	C	E	F	G
Carbide Tipped	HSS Spiral	Solid Carbide Spiral	Bit Diameter Finger Size	Max. Cutting Depth Max. Board Thickness	Shank Diameter	Overall Length	eBush	Comb Size
163	163	—	3/32"	3/8"	1/4"	2"	e8	3/8"
134	164	164C	1/8"	3/8"	1/4"	2 5/8"	e10	1/2"
135	165	165C	5/32"	5/8"	1/4"	2 7/8"	e7	5/16"
136	166	166C	3/16"	5/8"	1/4"	2 7/8"	e8	3/8"
138	168	168C	1/4"	3/4"	1/4"	3"	e10	1/2"
140-8	170	170C	5/16"	7/8"	8mm & 5/16"	2 3/4"	e7	5/16"
143	173	173C	3/8"	1"	3/8"	3"	e8	3/8"
160	180	180C	1/2"	1 1/4"	1/2"	3 1/2"	e10	1/2"

#### F3M (Metric)

A	B	C	E	F	G
Bit Diameter Finger Size	Max. Cutting Depth Max. Board Thickness	Shank Diameter	Overall Length	eBush	Comb Size
2	Leigh does not stock metric sized bits. Please contact your national distributor or dealer for Leigh.			e7	8
4				e7	8
6				e10	12
8				e7	8
10				e8	10
12				e10	12

#### F18 and F24 (Inches)

LEIGH BIT NO.			A	B	C	E	F	G
Carbide Tipped	HSS Spiral	Solid Carbide Spiral	Bit Diameter Finger Size	Max. Cutting Depth Max. Board Thickness	Shank Diameter	Overall Length	eBush	Comb Size
163	163	—	3/32"	3/8"	1/4"	2"	e8	3/8"
134	164	164C	1/8"	3/8"	1/4"	2 5/8"	e10	1/2"
136	166	166C	3/16"	5/8"	1/4"	2 7/8"	e8	3/8"
138	168	168C	1/4"	3/4"	1/4"	3"	e10	1/2"
143	173	173C	3/8"	1"	3/8"	3"	e8	3/8"
160	180	180C	1/2"	1"	1/2"	3 1/2"	e10	1/2"

#### F18M and F24M (Metric)

A	B	C	E	F	G
Bit Diameter Finger Size	Max. Cutting Depth Max. Board Thickness	Shank Diameter	Overall Length	eBush	Comb Size
3	Leigh does not stock metric sized bits. Please contact your national distributor or dealer for Leigh.			e10	12
5				e8	10
6				e10	12
10				e8	10
12				e10	12

**Note:** For wider boards, see [www.leighjigs.com](http://www.leighjigs.com) Click on Support > Technical Bulletins > Finger /Box Joints on Wider Boards. This bulletin applies to F1, F2 and F3 Templates.

## *Appendix III*

# **Template Parts**

***See parts list and drawing on the following pages.***

***When ordering parts, please quote the template model (inch or metric), serial number, part number, part description and quantity required.***

For quick reference, record your template's serial number here.

When ordering parts, please quote the template model (inch or metric), serial number, part number, part description and quantity required.

### F18, F18M, F24, F24M

PART NUMBER	QUANTITY PER TEMPLATE	PART DESCRIPTION
3418	1	F18 "Inch" Template
3418M	1	F18 "Metric" Template
3424	1	F24 "Inch" Template
3424M	1	F24 "Metric" Template
3419	1	F18 "Inch" Template Bar with glides (3140)
3419M	1	F18 "Metric" Template Bar with glides (3140)
3425	1	F24 "Inch" Template Bar with glides (3140)
3425M	1	F24 "Metric" Template Bar with glides (3140)
3360	1	RH Scale Assembly (RH in $\frac{3}{8}$ " & 10mm mode)
3370	1	LH Scale Assembly (LH in $\frac{3}{8}$ " & 10mm mode)
7210	2	Scale Nut
7215	2	Scale Washer
7220	2	Scale Wedge
7225R	2	Scale Lock Screw #8-32
7250	2	Scale Thumbscrew
7255	2	Nylon Flat Washer $\frac{13}{64}$ " x $\frac{7}{16}$ " x .062"

### F3, F3M

PART NUMBER	QUANTITY PER TEMPLATE	PART DESCRIPTION
3003	1	F3 "Inch" Template
3003M	1	F3M "Metric" Template
3013	1	F3 "Inch" Template Bar with Glides (3140)
3013M	1	F3 "Metric" Template Bar with Glides (3140)
3063	1	F3/F3M RH Scale Assembly (RH in $\frac{1}{2}$ " & 12mm mode)
3073	1	F3/F3M LH Scale Assembly (LH in $\frac{1}{2}$ " & 12mm mode)
e7	1	$\frac{7}{16}$ " e-Bush and nut
3156	1	Allen Wrench for Set Screws
3110R	2	Scale Lock Set Screws

### COMMON TO ALL F-TEMPLATES

PART NUMBER	QUANTITY PER TEMPLATE	PART DESCRIPTION
e8	1	$\frac{1}{2}$ " e-Bush and nut
e10	1	$\frac{5}{8}$ " e-Bush and nut
3120	1	Template Pin with Tie (3130)
3130	1	Template Pin Tie
3140	4	Template Bar Glides
3470	1	User Guide, combined inch & metric
730V	1	Pin Wrench

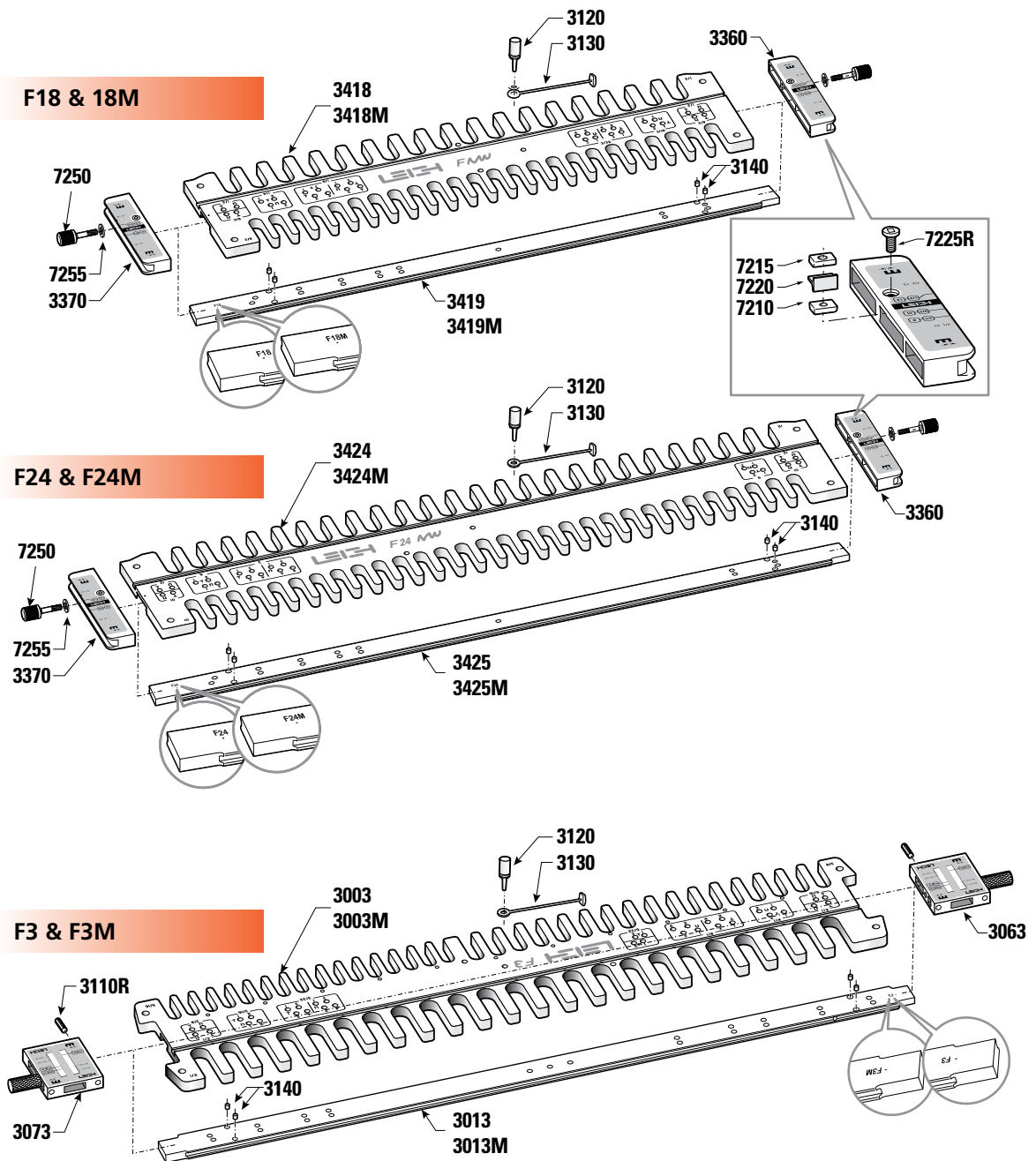

e7 & Nut  
only with  
F3 & F3M



e8 & Nut  
with all  
templates



e10 & Nut  
with all  
templates

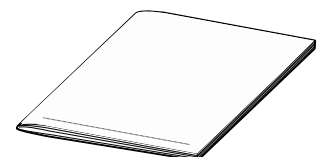





## Appendix IV

# Customer Support

**Our Commitment to You** Leigh Industries takes pride in its commitment to providing excellence in customer service and support. This user guide is designed to provide you with the answers to any questions you have. However, if you require assistance, please feel free to contact our technical support staff or a distributor listed below.

### Manufacturer: Canada/USA

#### TEL/FAX

**Customer Service  
and Technical Support**  
800-663-8932 (Canada/USA)  
604-464-2700 (Tel.)  
604-464-7404 (Fax.)

#### EMAIL/WEB

**Customer Service**  
leigh@leighjigs.com  
**Technical Support**  
help@leighjigs.com  
**Website**  
www.leighjigs.com

**NOTE:** Email can be useful, but technical queries usually raise queries from us. A phone call is the quickest and most convenient way to get queries answered, either directly to Leigh (toll free in N. America) or to your national distributor. –*Thanks!*

#### MAILING ADDRESS

Leigh Industries Ltd.  
P.O. Box 357  
Port Coquitlam, B.C.  
Canada V3C 4K6

#### LOCATION

Leigh Industries Ltd.  
1615 Industrial Ave.  
Port Coquitlam, B.C.  
Canada V3C 6M9

### Distributors

#### AUSTRALIA & NEW ZEALAND

Maxis Distribution  
128 Ingleston Rd., Wakerley, Qld., 4154  
Australia  
Tel: 1300 767 366  
Tel (Int.) +61 7 3292 0392  
Email: info@maxis.com.au  
Web: www.maxis.com.au

#### CHINA

Harvey Industries Co., Ltd.  
68-10 Suyuan Avenue  
Jiangning District Nanjing 211100, China  
Tel: (0)86 5792 8869 / 5792 8021  
Fax: (0)86 5792 8826  
Email: caozhi@harvey.cn  
Website: www.harveyworks.cn

#### FRANCE

Ets Bordet  
23 Rue Traversiere 93556  
Montreuil Cedex, France  
Tel: 01 48 58 28 39  
Fax: 01 48 58 48 58  
Email: info@bordet.fr  
Web: www.bordet.fr

#### GERMANY, AUSTRIA & SWITZERLAND

Hacker GmbH  
Holzbearbeitungsmaschinen  
Traberhofstraße 103 D-83026 Rosenheim  
Deutschland  
Tel: 08031 269650  
Fax: 08031 68221  
Email: hacker.rosenheim@t-online.de  
Web: www.leigh.de

#### ITALY

Ferrari Macchine Legno SRL  
Via Gallarata 74/76/78  
20019 Settimo M.se (MI) Italy  
Tel: 39 02 335 010 95  
Fax: 39 02 335 005 27  
Email: info@ferrarimacchine.com  
Web: www.ferrarimacchine.com

#### JAPAN

Off Corporation Inc.  
323-1 Yanbara, Shimizu-ku, Shizuoka-shi  
Shizuoka-ken, Japan 424-0002  
Tel: 81-50-3816-0115  
Fax: 81-54-367-6515  
Email: info@off.co.jp  
Web: www.off.co.jp

#### KOREA

Leigh Korea  
1st Floor, Yongyu Building, 25-3  
Neung Pyung-Ri, Opo-Eup, Kwangju-Si  
Kyunggi-do, Korea  
Tel: 82 (0) 70-8252-0988  
Fax: 82 (0) 31-765-5602  
Email: maengha@leigh.co.kr  
Web: www.leigh.co.kr

#### NETHERLANDS, BELGIUM & LUXEMBOURG

Houtbewerking Krielaart  
9217RR Nijega, Netherlands  
Tel: +31 512 354 770  
Email: gerard@gkrielaart.nl  
Web: http://www.leighjigs.nl

#### RUSSIA

Unicom Ltd.  
Nikitskij Boulevard 12  
Moscow, 119019, Russia  
Tel: 7 (495) 690 0454  
Email: info@leighjigs.ru  
Web: www.leighjigs.ru

#### SOUTH AFRICA

Hardware Centre  
PO Box 4059, Randburg 2125  
South Africa  
Tel: +27 011 791-0844/46  
Fax: +27 011 791-0850  
Email: info@hardwarecentre.co.za  
Web: www.hardwarecentre.co.za

#### SWEDEN

Toolbox Sweden AB  
Bruksgatan 3, S-597 30  
Atvidaberg, Sweden  
Tel: 46 120 854 50  
Fax: 46 120 854 69  
Email: info@toolbox.se  
Web: http://www.toolbox.se

#### UNITED KINGDOM & IRELAND

Axminster Tools & Machinery  
Headquarters, Unit 10, Weycroft Avenue  
Axminster, Devon  
EX13 5PH United Kingdom  
Tel: 0800 371822  
Text: 07786 200699  
Email: cs@axminster.co.uk  
Web: www.axminster.co.uk/leigh

