

CHAPTER 7

Router Table Operation

This chapter assumes you have set up your jig following the Mounting & Assembly instructions in Chapter 4, Steps 4-17 to 4-22. You should also be familiar with all procedures in this user guide.

IMPORTANT SAFETY NOTE

Before using your Leigh B975, you must have completed the preparatory steps listed in the previous pages, including reading the jig safety recommendations in Chapter 2.

7-1 Getting Started The B975 can be used to rout box joints on a router table, on boards up to a maximum width of 9-11/16" [246mm]. This example uses 3/4" box joints on 3/4" thick boards. Procedures for routing 1/2" and 3/4" joints are identical.

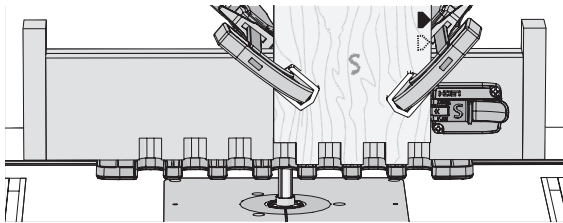

7-2 Parts Required 3/4" and 1/2" box joints are routed with the included Leigh No.160 1/2" straight bit and the Leigh e10 guide bushing (eBush). **No other bit diameter and guide bushing combination may be used.** Maximum board thickness for both joint sizes is 13/16" [20.6mm]. Depth of cut can be increased beyond the board thickness for raised joints. **Note:** Optional 1/2" diameter spiral upcut bits may also be used.

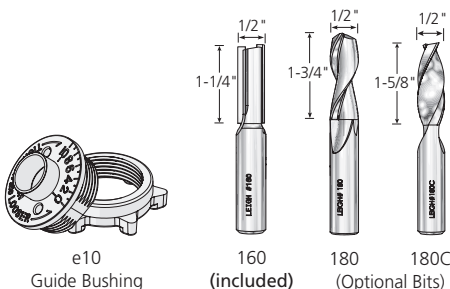

Bit Cutting Depth

Bit Diameter	1/2"
Item No. Carbide Tipped	160
Item No. Spiral HSS (Optional)	180
Item No. Spiral Solid Carbide (Optional)	180C

Depth of Cut	0"	1/4"	1/2"	3/4"	13/16"
0"					
1/4"					
1/2"					
3/4"					
13/16"					

7-3 Router Table Requirements Router tables are typically used with a bearing or fence, however, the Leigh B975 is guided around a guide bushing in the router table. Leigh eBushes (guide bushings) are designed around the 1-3/8" diameter industry standard. See specifications below.

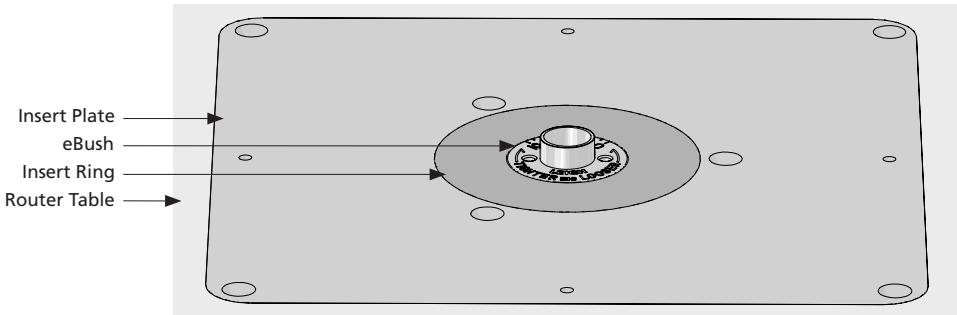
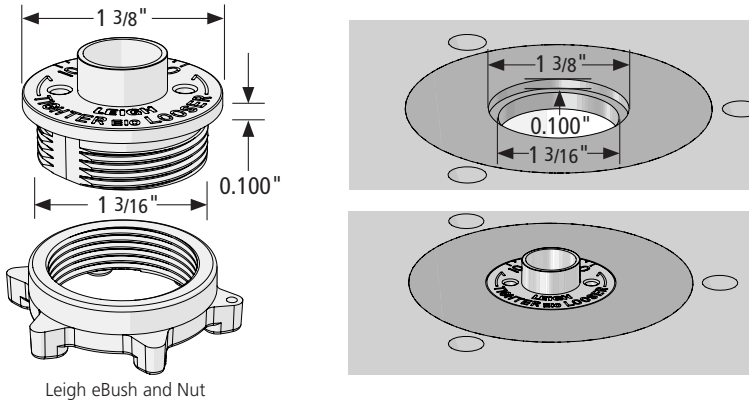

7-4 Insert Ring To install the eBush to your router table insert plate, you may need a 1-3/8" diameter counter bore insert ring. Check with your router table or insert plate (router lift) manufacturer, as to what adaptation, if any, is required.

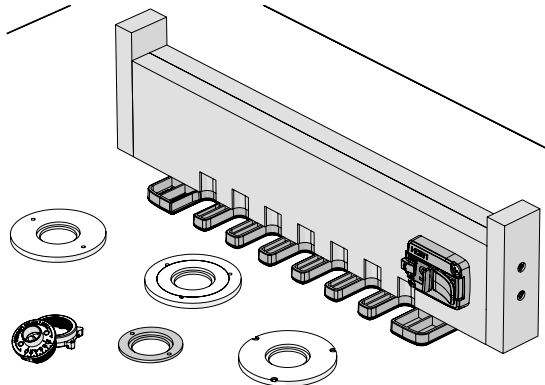

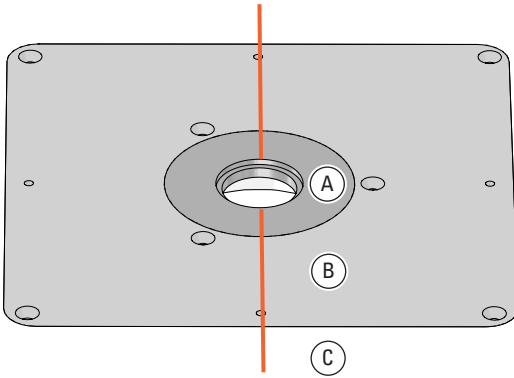

7-5 Draw a reference line with a permanent pen on the router table, centered on the guide bushing opening at 12 o'clock and 6 o'clock (shown in red for clarity only).

This will ensure correct orientation of the eBush to the insert ring **A**, the insert plate **B**, and the router table **C**.

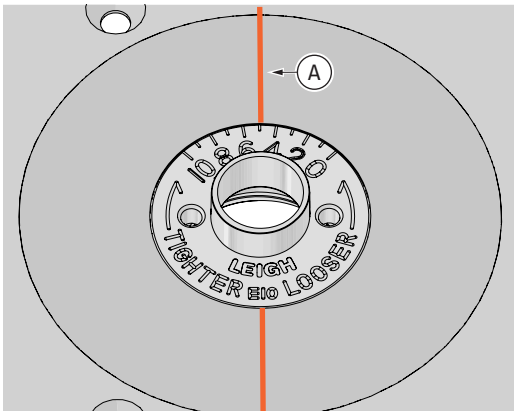

7-6 Install the e10 guide bushing in the router table. Turn the e10 to align the 5 position with the line **A** you've just drawn.

Using an initial setting of 5 allows adjustment for a looser or tighter joint fit. This line will also help you guide the jig.

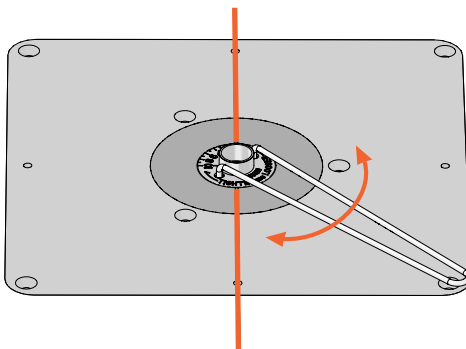

7-7 eBush adjustments are made with the included pin wrench. Markings on the eBush indicate which way to turn it for a looser or tighter fit. See Chapter 3.

Remember, every time you adjust the eBush you must re-tighten the eBush nut.

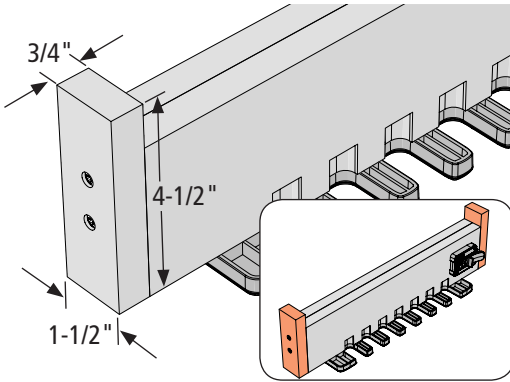

7-8 Before using the jig on a router table, handles must be attached to the ends of the beam. Cut two pieces of wood to the dimensions indicated and attach with screws.

The handles will keep your fingers safely away from the bit and help control the jig during routing.

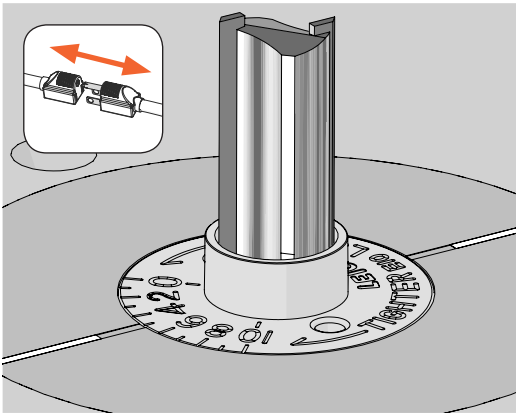

7-9 With the router unplugged, install the No. 160 straight bit to the router and tighten the collet nut.

⚠ Be sure the bit spins freely within the guide bushing before reconnecting the power.

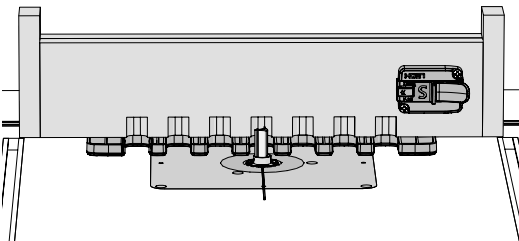

7-10 Reminder: If you haven't already done so, you must rout grooves on each side of the beam (see Chapter 4, steps 4-17 to 4-22).

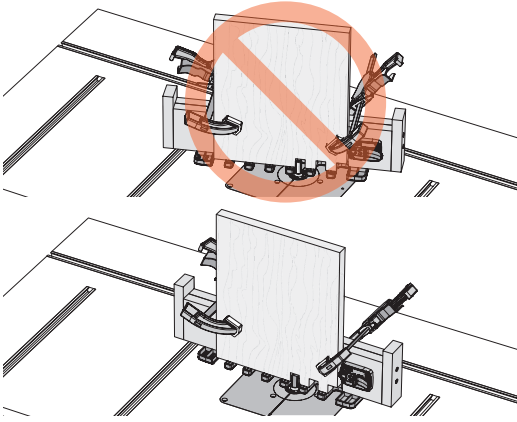

7-11 Do not turn or rotate the jig as you rout. Keep the jig parallel to the router table and go straight in and straight out of each template opening.

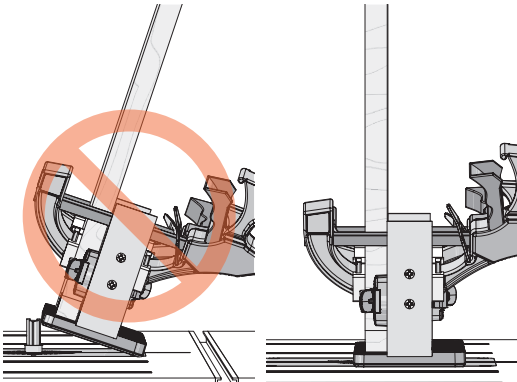

7-12 Never tilt the jig. Keep the jig flat on the router table at all times.

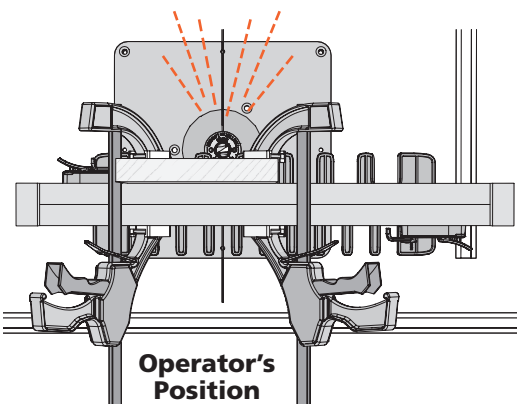

7-13 Chips and sawdust are thrown out at high speed. Always stand and use the jig away from chip and sawdust ejection.

7-14 Joint layout Symmetrical joints have pins (A) on both edges of the pin board, and sockets (B) on both edges of the socket board. Asymmetrical joints have a socket (C) on one edge and a pin (D) on the other edge of each board.

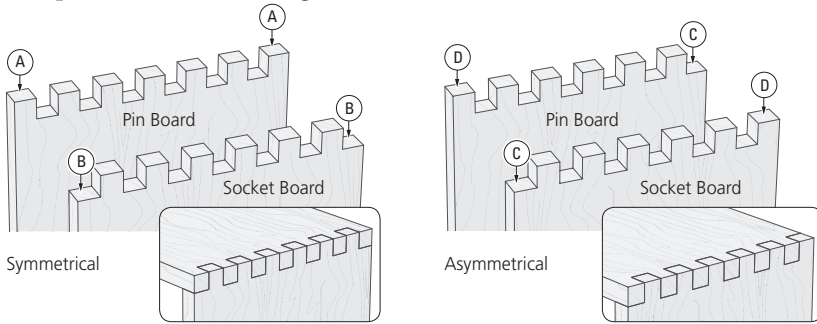

7-15 Board Width Selection Board widths are determined by the total number of pins and sockets in the joint design and whether the joint is symmetrical or asymmetrical. Use this chart to determine board widths up to 9-11/16" [246 mm].

Symmetrical Board Widths for 3/4" Box Joints

Total Pins & Sockets	3	5	7	9	11	13
Inches	2 3/16"	3 11/16"	5 3/16"	6 11/16"	8 3/16"	9 11/16"
Millimeters	56	94	132	170	208	246

Asymmetrical Board Widths for 3/4" Box Joints

Total Pins & Sockets	4	6	8	10	12
Inches	2 15/16"	4 7/16"	5 15/16"	7 7/16"	8 15/16"
Millimeters	75	113	151	189	227

Symmetrical Board Widths for 1/2" Box Joints

Total Pins & Sockets	3	5	7	9	11	13	15	17	19
Inches	1 7/16"	2 1/2"	3 1/2"	4 1/2"	5 9/16"	6 9/16"	7 5/8"	8 5/8"	9 5/8"
Millimeters	37	63	89	115	141	167	195	219	245

Asymmetrical Board Widths for 1/2" Box Joints

Total Pins & Sockets	4	6	8	10	12	14	16	18
Inches	1 15/16"	3"	4"	5 1/16"	6 1/16"	7 1/16"	8 1/8"	9 1/8"
Millimeters	50	76	102	128	154	180	206	232

7-16 Board widths indicated in the chart on the previous page will produce full size pins and sockets at each board edge, for symmetrical or asymmetrical joints. Symmetrical joint board widths may be reduced as required, resulting in smaller but equally sized pins and sockets at each board edge. If board widths are reduced for asymmetrical joints, one edge of the board will have a full size pin and socket while the other board edge will have a smaller pin and socket. This may result in an unattractive joint.

Symmetrical

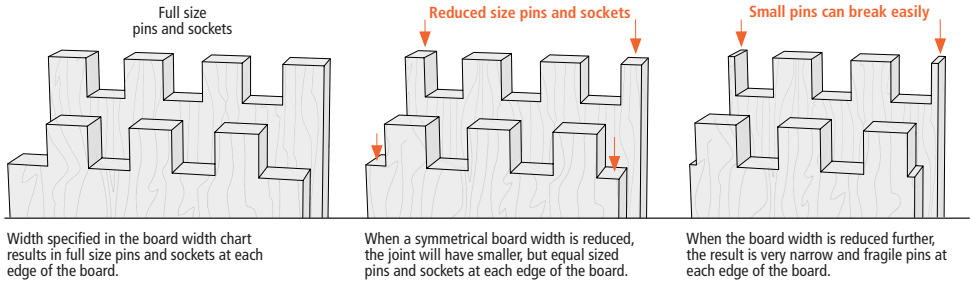

Asymmetrical

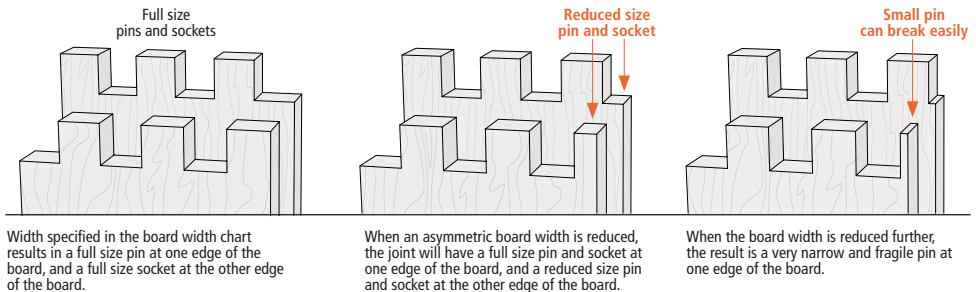

⚠ IMPORTANT: Read the whole chapter before routing any boards.

7-17 Making a Box

Prepare four similar boards $\frac{3}{4}$ " thick \times $5\text{-}\frac{3}{16}$ " wide by about 12" long [19mm \times 133mm \times 305mm], and two test boards, $\frac{3}{4}$ " thick by about 4" [100mm] wide.

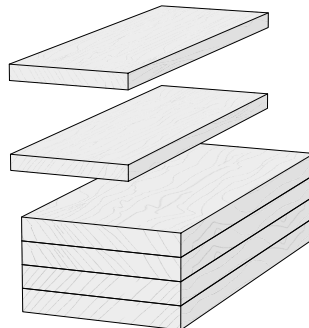

Note: Boards of different thicknesses may also be joined.

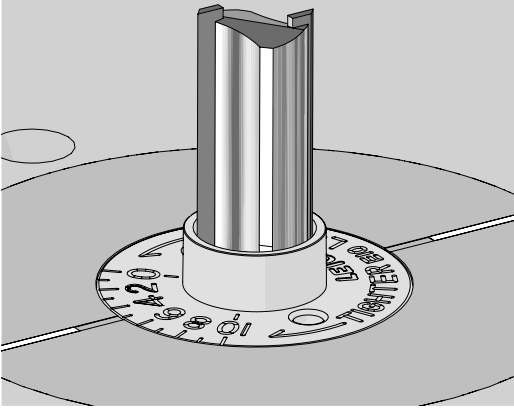

7-18 Routing a Test Joint Test joints are routed with the eBush set at the 5 position. Tighten the eBush nut after each guide bushing adjustment.

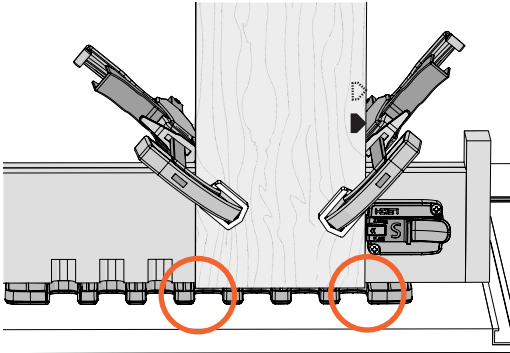

7-19 Center a test board on the left side of the 3/4" template, leaving an equal amount overhang on each edge of the board.

Clamp the board in place.

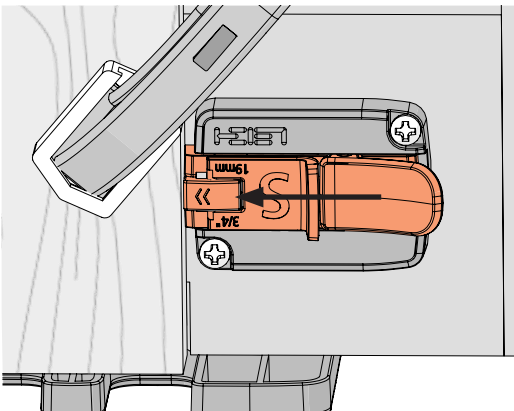

7-20 Slide the socket board stop until it touches the edge of the board. Secure the side stop with the thumb lock.

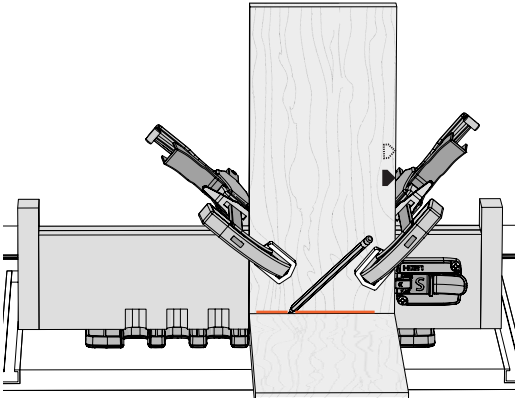

7-21 Socket and pin boards may differ in thickness. Always use the mating pin or socket board to determine the depth of cut. In this case, hold a pin board flush against the template and draw a line on the board, indicating depth of cut.

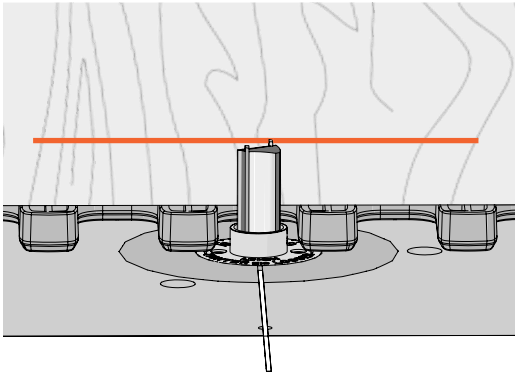

7-22 Place the router on the jig and adjust the tip of the bit up or down until it's at the center of the line. Rotate the bit and collet to ensure it spins freely and does not contact the eBush.

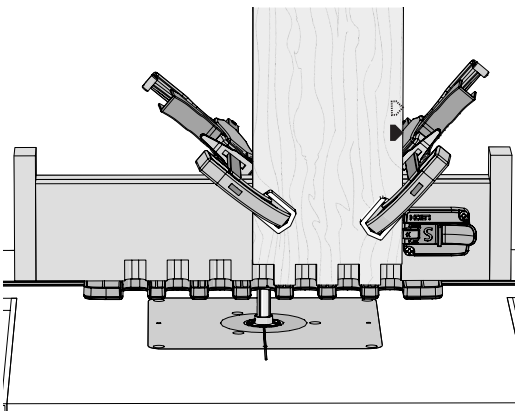

7-23 Rout straight in and out of each template opening. Be sure the e10 guide bushing touches the left side of each template opening on the way in, and the right side on the way out. **Do not rotate the jig.**

Chips and sawdust can accumulate between the template openings. Check each routed slot to ensure it has been routed completely. Remove the board.

7-24 Place the second test board against the side stop and clamp in place. Rout the board.

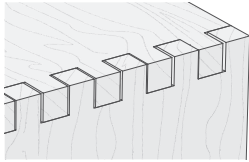
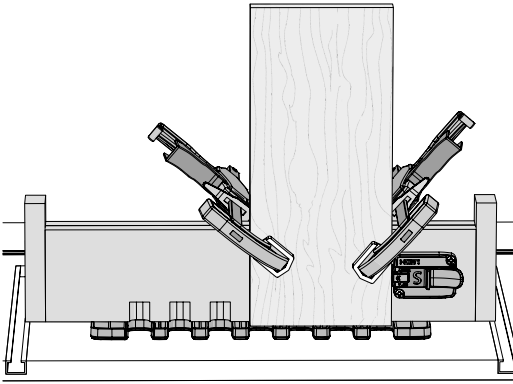

TOO LOOSE

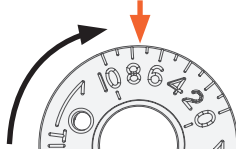

TIGHTEN

7-25 Joint Fit Adjustment

Assemble the test boards. If the joint is too loose, use the pin wrench and turn the eBush to a higher number and rout two fresh board ends.

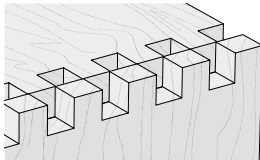

TOO TIGHT

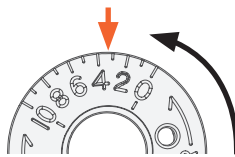

LOOSEN

If the joint is too tight, turn the eBush to a lower number and rout two fresh board ends.

Re-tighten the eBush nut after each guide bushing adjustment.

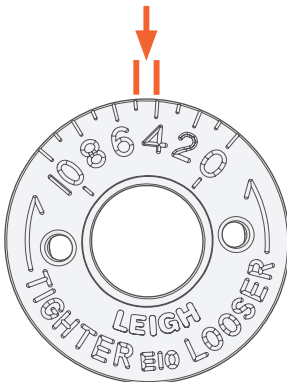

7-26 Each increment on the eBush changes the joint glue line fit by 0.002" [0.05mm]. Half an increment, a mere 0.001"!

SAMPLE

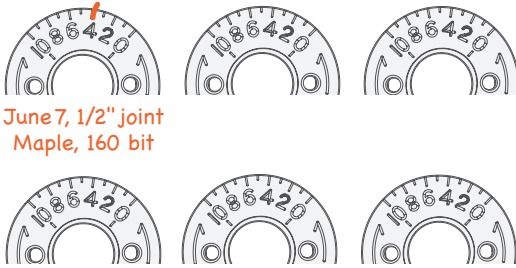

7-27 Use these eBush diagrams to record the settings you used to achieve perfect joint fit. The first eBush is an example of how to record your setting.

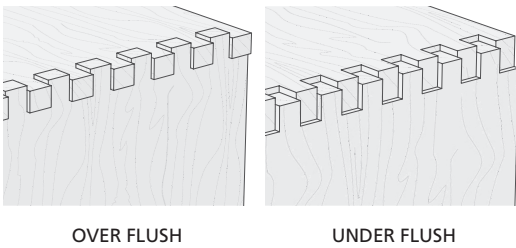

7-28 Joint flushness is determined by the depth of cut.

If the joint is over flush, lower the bit to make a shallower cut.

If the joint is under flush, raise the bit to make a deeper cut.

Rout new test joints until fit and flushness are perfect before routing the final boards.

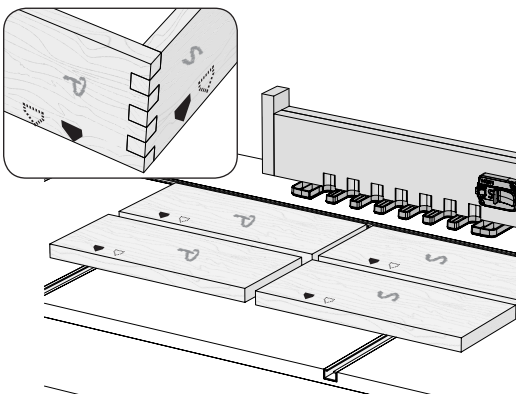

7-29 Making a Box

Lay out the four boards and mark two pin boards and two socket boards. Also, indicate the common board edges that will go against the side stop.

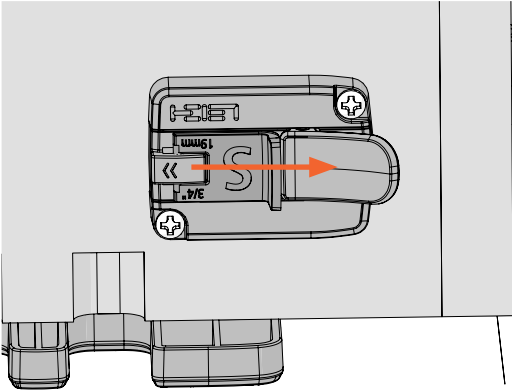

7-30 Before clamping the first socket board, ensure the socket board stop is fully retracted, and locked in place.

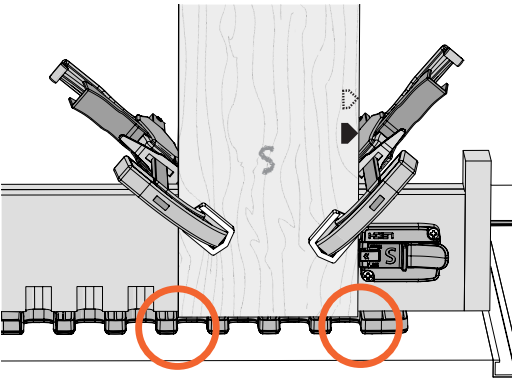

7-31 With the left edge of the board in the first template opening, position the socket board on the jig, leaving equal amounts of the board showing at each edge.

Clamp the jig in place.

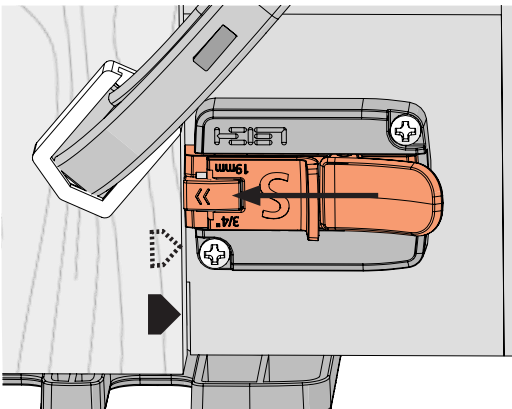

7-32 Slide the socket board stop until it touches the edge of the board, and secure with the thumb lock.

The side stop remains locked in place for all socket and pin board routing.

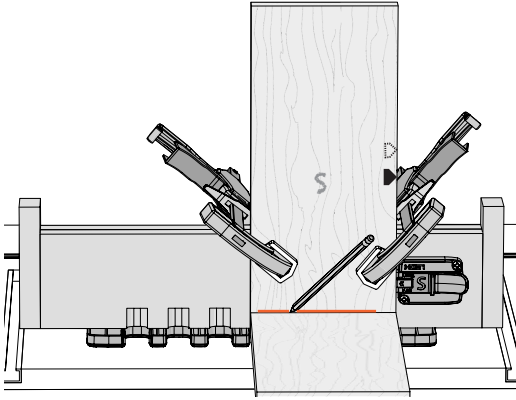

7-33 Hold a pin board flush against the template and draw a line on the board, indicating depth of cut.

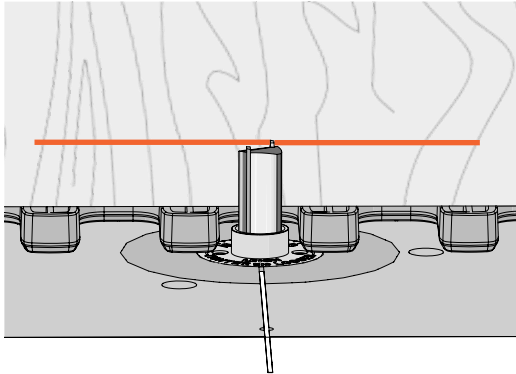

7-34 Adjust the tip of the bit up or down until it's at the center of the line.

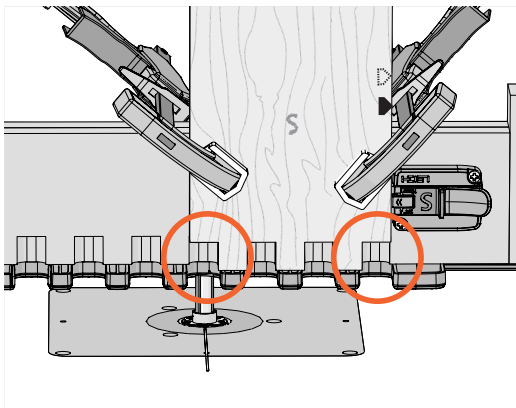

7-35 Rout straight in and out of each template opening. Be sure the e10 guide bushing touches the left side of the template opening on the way in, and the right side on the way out. **Do not rotate the jig.**

There will now be a full socket at each edge of the board.

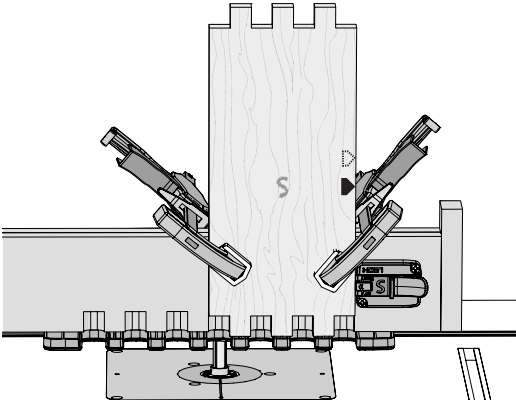

7-36 Unclamp and flip the first socket board end for end, keeping the same board edge against the side stop, and clamp in place. Rout in each template opening.

Repeat the procedure for the second socket board.

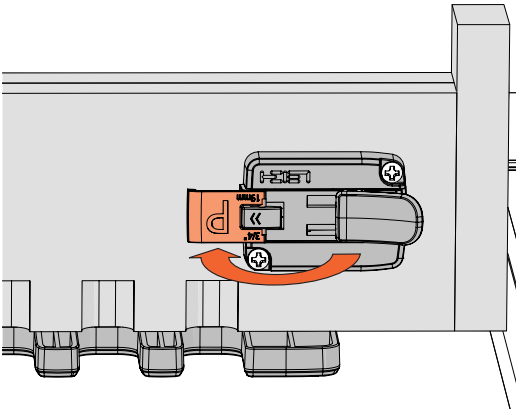

7-37 Routing the Pin Board

Flip the side stop to the pin board stop position.

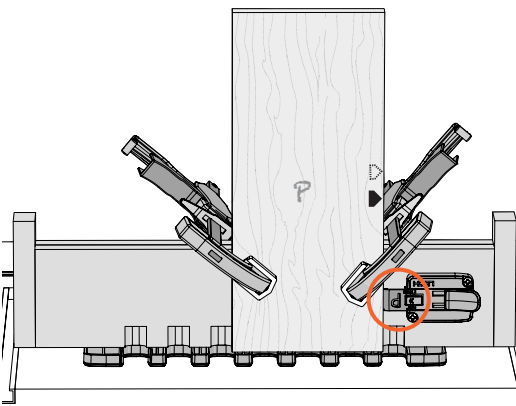

7-38 Place the first pin board on the jig with its edge touching the pin board stop and clamp in place.

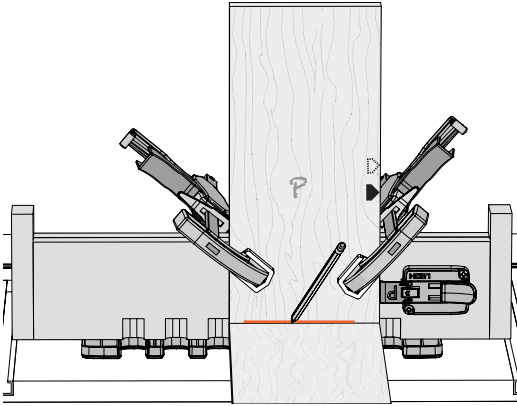

7-39 Hold a socket board flush against the template and draw a line on the board, indicating depth of cut.

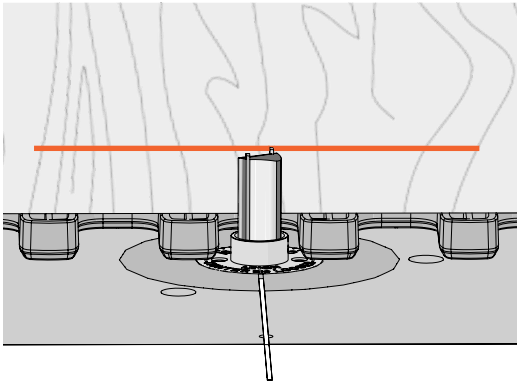

7-40 Adjust the tip of the bit up or down until it's at the center of the line.

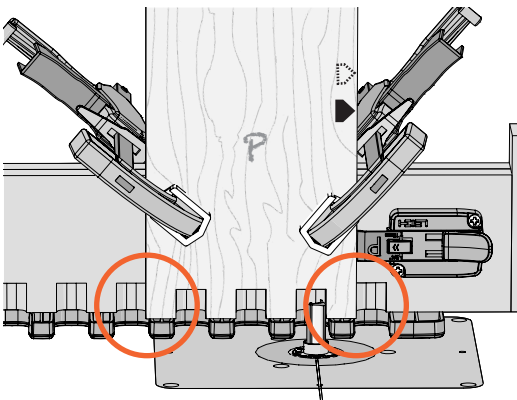

7-41 Rout straight in and out of each template opening. Be sure the $\epsilon 10$ touches the left side of the template opening on the way in, and the right side on the way out. **Do not rotate the jig.**

There will now be a full pin at each edge of the board.

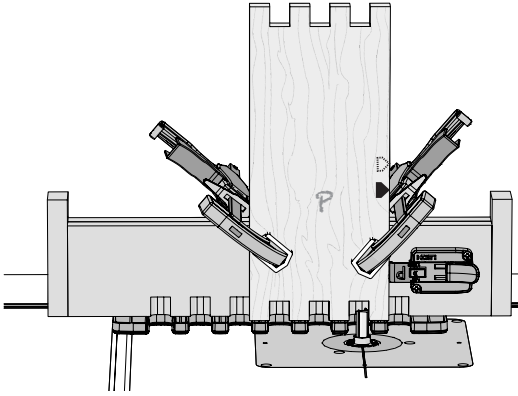

7-42 Unclamp and flip the first pin board end for end, keeping the same board edge against the side stop, and clamp in place. Rout in each template opening.

Repeat the procedure for the second pin board.

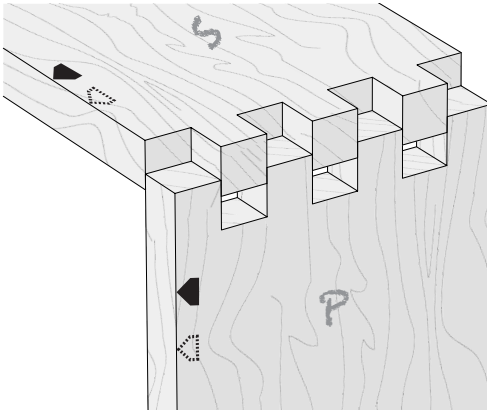

7-43 Remove the board from the jig and assemble the joint, keeping the marked board edges aligned. ■