

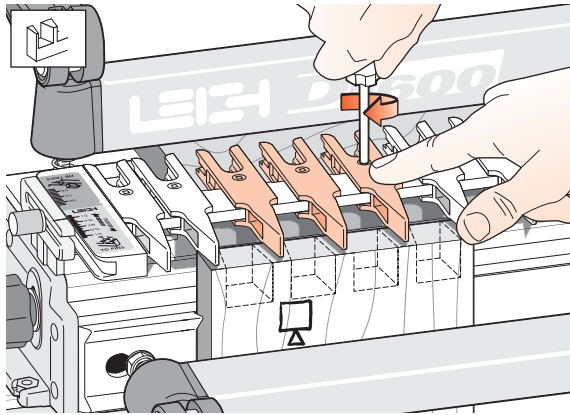



D1600 CHAPTER 13



Quick Reference Through Dovetails

You haven't used the jig for a while and just need reminding of the basics. Here they are for Through Dovetails.

**13-1**

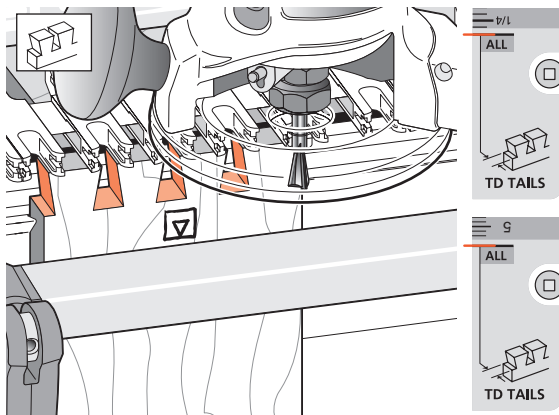
Through dovetails are laid out in the  TD PINS mode with the finger assembly slightly raised above the spacer board and the pin board. The outside face  of the TD pins is away from the jig body.

**13-2**

TD tail boards are clamped vertically in the jig. The inside face  of the TD tails is away from the jig body. The finger assembly is in the  TD TAILS mode, set on the "ALL" setting. There is only one setting in this mode.

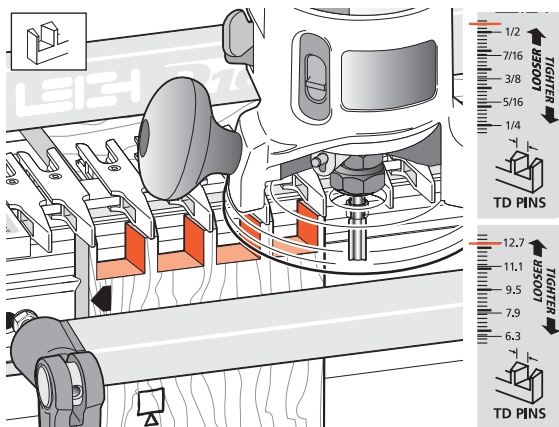
**13-3**



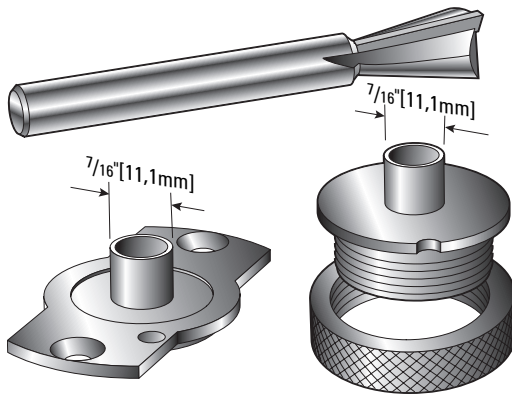

The finger assembly is in the  TD PINS mode, with the scale set to a recorded setting (see detailed instructions to fit on pages 45-48). TD pins are cut with a straight cutter; the only time a straight cutter is used in dovetailing.

This is the only one of the four main modes that puts the outside face  of the board away from the jig body.

**13-4**

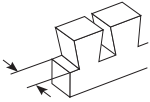
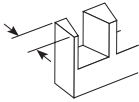
Through dovetail tails are always cut with an 8° dovetail cutter to match the 8° guide-finger.

All dovetail routing on the D1600 is done with a $\frac{7}{16}$ " [11,1mm] guidebush.

 Thickness of Tail Board	 Thickness of Pin Board	 Dovetail Cutter	 Straight Cutter	 Guidebush Diameter
up to $\frac{13}{16}$ " [21]	$\frac{1}{2}$ " - $\frac{13}{16}$ " [12-20]	No.80-8	No.140-8	$\frac{7}{16}$ " [11,1]
up to $\frac{13}{16}$ " [21]	$\frac{3}{8}$ " - $\frac{5}{8}$ " [10-16]	No.75-8	No.140-8	
up to $\frac{13}{16}$ " [21]	$\frac{1}{4}$ " - $\frac{1}{2}$ " [6-13]	No.70-8	No.140-8	
up to $\frac{13}{16}$ " [21]	up to $\frac{3}{8}$ " [10]	No.60-8	No.140-8	
up to $\frac{13}{16}$ " [21]	up to $\frac{1}{4}$ " [6]	No.50-8	No.140-8	

Numbers in brackets are millimetres

13-5

Here is a quick reference selection chart for through dovetail cutters and guidebushes. Please study the cutter and guidebush selection appendices for a full explanation. ■

