

D4R Pro - CHAPTER 6

Wood Preparation

"Garbage In - Garbage Out"...

This adage of the computer age stands equally true for dovetail jigs.

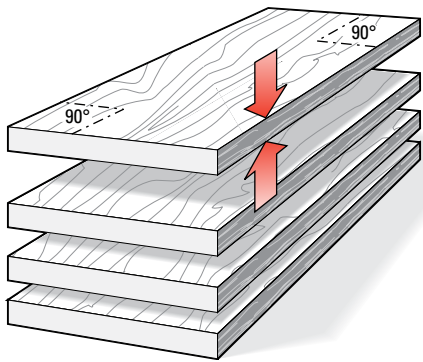

6-1 It is vital for accurately aligned joints that stock used on the Leigh jig must be prepared straight, flat, of even thickness and equal widths, with square ends and edges. *Note that plywood is generally unsuitable for routing because of tearout problems.*

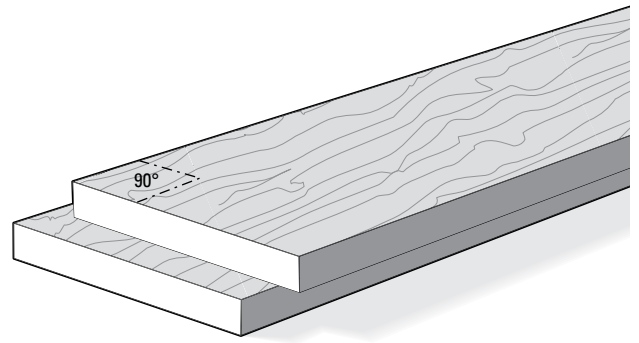

6-2 You will want to test the jig, so prepare some $\frac{3}{4}$ " x $5\frac{1}{2}$ " [20x140mm] boards. Cut them to length as you need them for the jig tests you want to perform. Use them for practice with the jig's various joint modes so you can see how the different modes work. Remember, though, that two boards of different thicknesses can be joined just as easily.

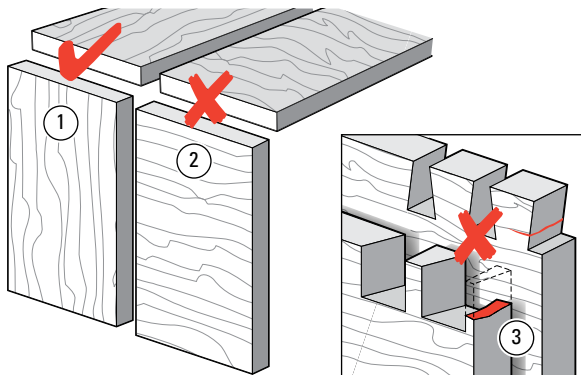

6-3  Dovetail joints are intended for joining end-grain to end-grain ①. Attempting to cut dovetails in side-grain ② does not work because:

- A. The wood will tear out badly when routing.
- B. Even if you could rout them, the pins and tails would easily break off across the short grain ③, either during or soon after the assembly when the boards start expanding or contracting at different rates. ■

This page is left blank intentionally.