



Watch the Online Instructional Video

Scan the QR Code for instant video

To view the instructional video online go to Leightools.com support section. Stream while you work to your smart phone or tablet.



Scan QR Code

D4R Pro - CHAPTER 2

Adjusting the Finger Assembly

The Finger Assembly is The Heart of The Leigh Jig

Spend a few minutes now to familiarize yourself with these simple adjustments.

Note: The first few times you use your jig, some fingers may "stick". This is normal. To "unstuck", loosen the finger screw approximately 3/4 of a turn. With the screwdriver still in the screw, press down firmly (on the screwdriver). This will loosen the finger locking wedge (you may feel a click). The finger will now move freely.

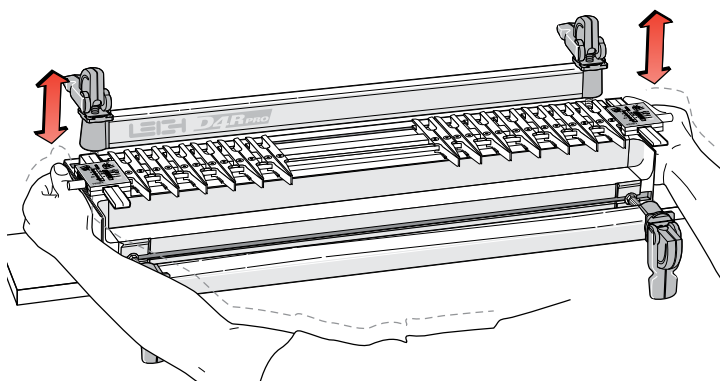

2-1 Practice adjusting the finger assembly height. Loosen the support bracket knobs and hold them firmly. Raise and lower the assembly evenly, keeping it level, and tighten the knobs to lock it at various heights.

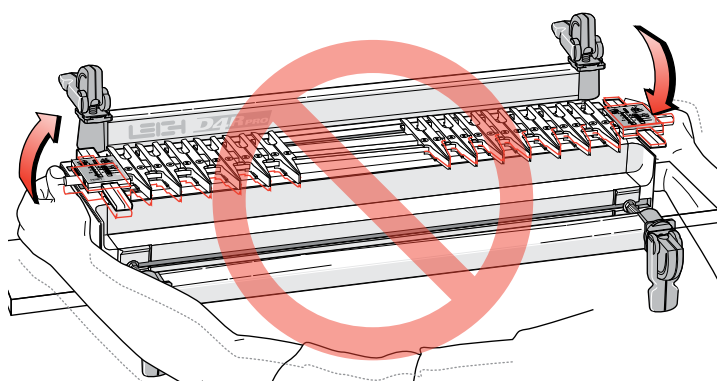

2-2 Do Not raise or lower one end of the finger assembly at a time.

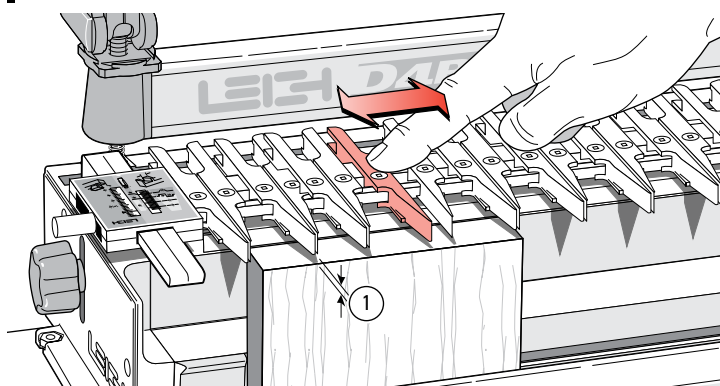

2-3 To practice adjusting the guide fingers, put a board in the front clamp. Always raise the finger assembly slightly, 1/8" [2mm] above the spacer board and or workpiece ①. This is essential to allow the fingers to move freely on the guide finger bar and ensures the fingers will be level and flush when locked up. To move guide fingers push on the middle to slide them along the guide finger bar.

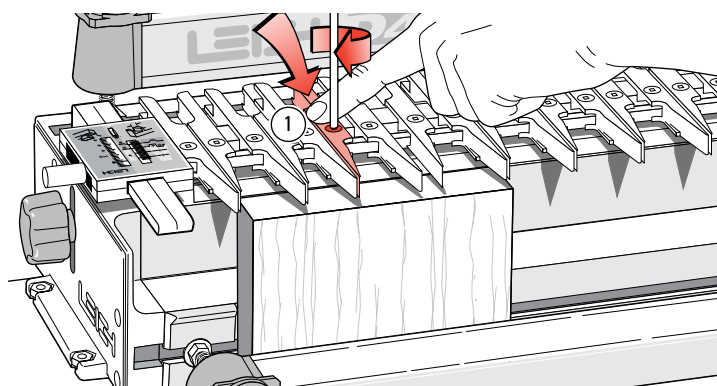

2-4 Loosen about half the guide fingers and practice unlocking, moving, positioning and re-locking them. Always press down lightly on the center of each guide finger ① when tightening the screws.

If after loosening a finger it "sticks" and doesn't slide, see header note above.

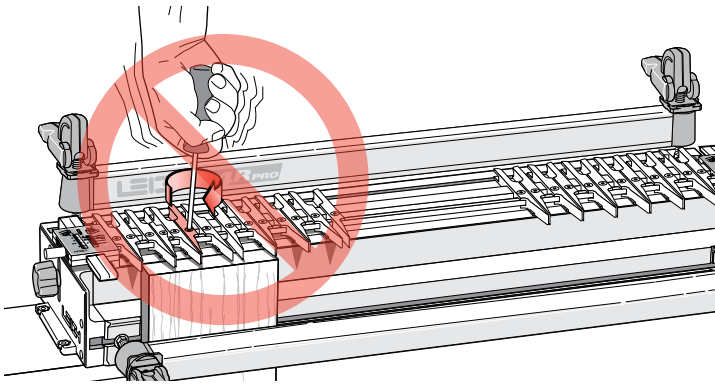

2-5 Do not over-tighten the guide finger locking screws. The Leigh screwdriver provided will give ample torque for easy lock-up without strain.

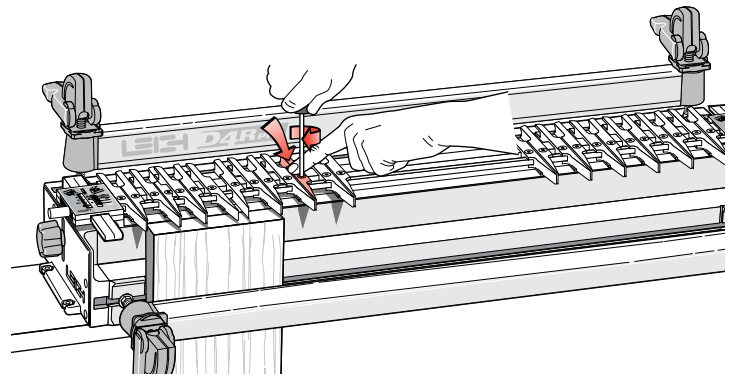

2-6 Always tighten unused guide fingers before routing, as router vibration will cause loose screws and wedge nuts to fall out and be lost.

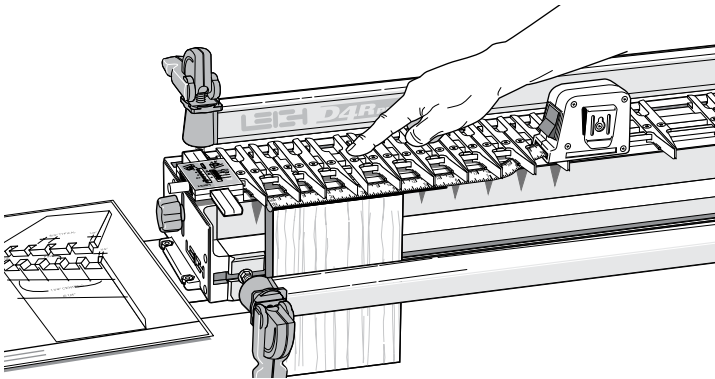

2-7 You can adjust the guide fingers by eye, or by measurement to suit a set of plans.

Note: Always lower the finger assembly down onto the workpiece before routing. ■